

Informal Housing Thermal Comfort

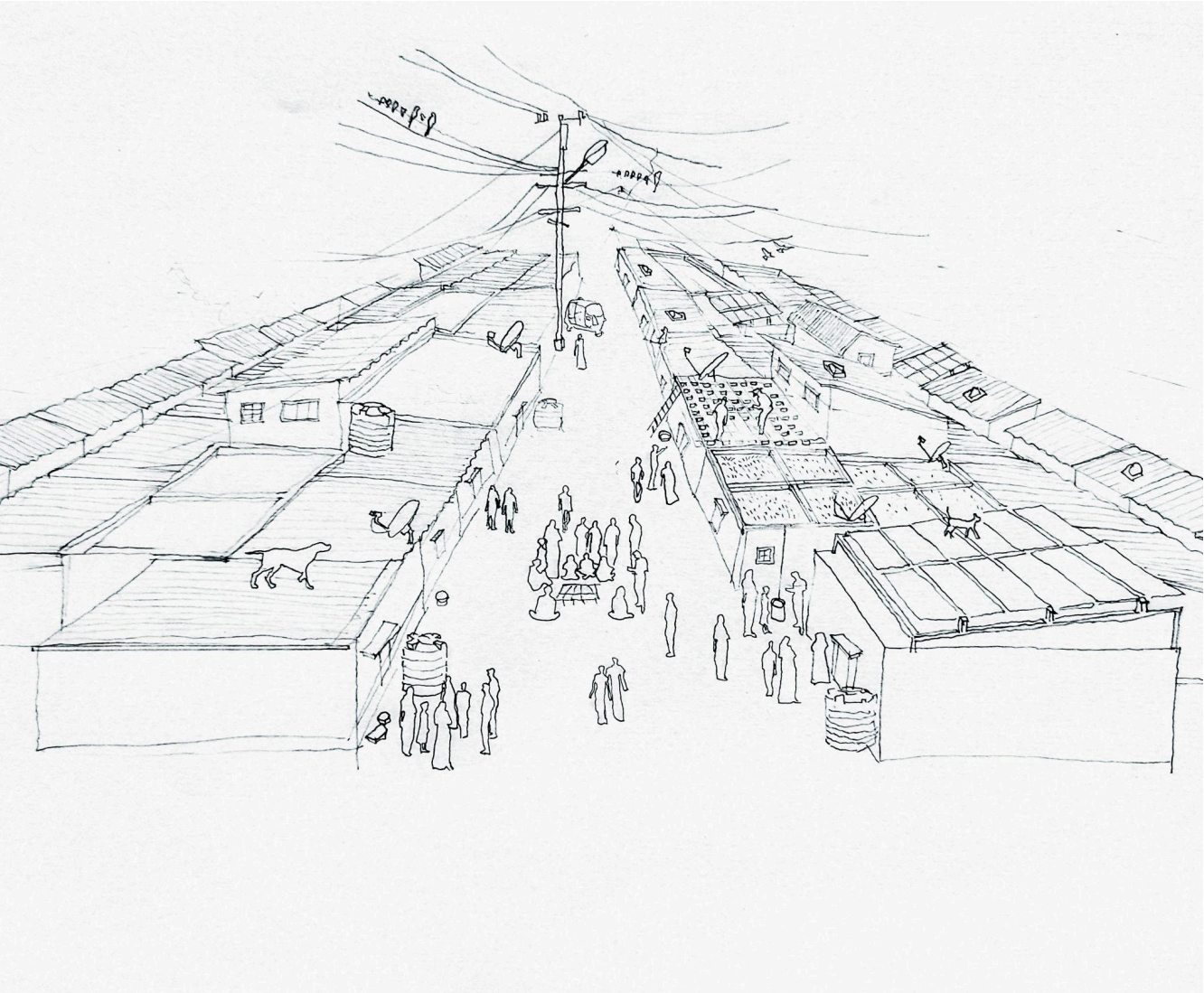

Insight Report

August 2025

Table Of Contents

1. Introduction.....	4
2. Community Engagement Insights.....	5
2.1. Community Engagement Process.....	5
2.2. Insights.....	7
2.2.1. Participatory Design Workshops.....	7
2.2.2. Partner Household Finalizing.....	8
2.2.3. Fabrication And Installation.....	8
2.2.4. Installation Performance Monitoring.....	9
2.2.5. Critical Feedback Workshop.....	9
3. Cooling Solution Refinement Insights.....	10
3.1. Water Filled PET Bottles.....	10
3.1.1. Prototype Testing Refinements.....	10
3.1.2. Pre-Fabrication Process Refinements.....	18
3.1.3. Fabrication Process Refinements.....	18
3.1.4. Installation Process Refinements.....	19
3.1.5. Post-Installation Process Refinements.....	19
3.2. Space Frame.....	19
3.2.1. Prototype Testing Refinements.....	19
3.2.2. Pre- Fabrication Process Refinements.....	21
3.2.3. Fabrication Process Refinements.....	21
3.2.4. Installation Process Refinements.....	22
3.2.5. Post-Installation Process Refinements.....	23
3.3. Rooftop Gardening (Passive Irrigation).....	23
3.3.1. Prototype Testing Refinements.....	23
3.3.2. Pre- Fabrication Process Refinements.....	29
3.3.3. Fabrication Process Refinements.....	29
3.3.4. Installation Process Refinements.....	30
3.3.5. Post-Installation Process Refinements.....	30
3.4. Internal Dynamic Barrier.....	30
3.4.1. Prototype Testing Refinements.....	30
3.4.2. Pre- Fabrication Process Refinements.....	31
3.4.3. Fabrication Process Refinements.....	32
3.4.4. Installation Process Refinements.....	32
3.4.5. Post-Installation Process Refinements.....	32
3.5. Vertical Cane Blind.....	33
3.5.1. Prototype Testing Refinements.....	33
3.5.2. Pre- Fabrication Process Refinements.....	35
3.5.3. Fabrication Process Refinements.....	35
3.5.4. Installation Process Refinements.....	35
3.5.5. Post-Installation Process Refinements.....	35
3.6. Biomass Panel.....	35
3.6.1. Prototype Testing Refinements.....	35

3.6.2. Pre- Fabrication Process Refinements.....	37
3.6.3. Fabrication Process Refinements.....	37
3.6.4. Installation Process Refinements.....	38
3.6.5. Post-Installation Process Refinements.....	38
3.7. Wood Wool Panel.....	38
3.7.1. Prototype Testing Refinements.....	38
3.7.2. Pre- Fabrication Process Refinements.....	40
3.7.3. Fabrication Process Refinements.....	40
3.7.4. Installation Process Refinements.....	41
3.7.5. Post-Installation Process Refinements.....	41

1. Introduction

The insights shared in this report are based on learnings from the 'Informal Housing Thermal Comfort Program' implemented in collaboration with 13 houses in Labour Colony, Sultanpuri, Delhi. The Colony comprises around 13000 houses with a population of 65000 people. Its formation began around the Year 1950 owing to the establishment of the Bhalla Factory which was initiated to work on fabricating and manufacturing parts of railway trains and gas cylinders. People started migrating to work in the factory from other areas in Delhi and other parts of India, shaping the area into a dense settlement by the year 1960. The Bhalla Factory was closed around 1980, however, by then other industries had started mushrooming in the area. The settlement therefore gradually became a residential place for people involved in a diversity of labour work, giving it the name Labour Colony. The settlement is tenure protected.

Houses in the settlement are mainly made of unplastered brick walls, with roofs primarily made of asbestos or stone slabs. The lanes are narrow and house structures lack ventilation - a minimum of two and, in most cases three walls are shared with adjacent houses.



Figure 1.1. Labour Colony

Cooling solution prototypes that were pre-tested in simulated conditions spanning - a) External Solar Shade + Radiant Barrier + Night Sky Radiation Space Frame, b) Internal Radiant Barrier Curtains c) PET Bottles d) PET Bottles in Crates e) Passive-Wicking Rooftop Garden f) Under Roof Insulation Panels, have been installed across 13 homes.

This report shares 'Community Engagement Insights' and 'Cooling Solution Refinement Insights' based on work conducted for implementation of the 'Informal Housing Thermal Comfort Program' in Sultanpuri.

2. Community Engagement Insights

2.1. Community Engagement Process

The engagement with community members in Labour Colony, Sultanpuri, Delhi, was initiated in July 2025. 3 participatory design workshops were conducted, with 25 people spanning men, women and youth participating in the workshops. The workshops provided a space for community members to share their thoughts on the proposed cooling solution designs.



Figure 2.1. Participatory Design Workshop

The participatory design workshops were followed by house audits to assess the suitability of a given cooling solution for a given house structure. The assessment results supported shortlisting 17 partner households from the 24 who participated in the participatory design workshop. A workshop was organised to share the results of the assessment with all participants. Of the 17 households only 10 agreed to be part of the project, primarily owing to reasons such as them being tenants and scepticism towards having the proposed solutions retrofitted to their house structures, therefore, a round of door-to-door visits were conducted to shortlist 3 more households. The process of identifying the additional houses was supported by a few people from the community owing to the rapport built between the project team and community members. An overview of the proposed solutions and details of installations were shared with residents whose homes were visited to gather

their thoughts on the proposed solutions. This process led to the identification of 5 additional homes who were willing to participate in the project.



Figure 2.2. Door-to-door visits for partner household identification

This was followed by house audits in homes of all 15 people, who expressed their willingness to be part of the project. Of the 15 homes, 13 homes were shortlisted to have the cooling solutions installed in their homes. The shortlisting was based on two parameters: a) The assessment of the suitability of a given solution for a particular house structure based on data collected through house audits b) Residents preference for a proposed solution. The shortlisting was followed by sharing the solution finalized for a particular household. Partnership agreement forms were signed with all households who agreed to have the thermal comfort solutions retrofitted to their roofs.

Thereafter, installation details including the duration, start and ending date of installations were shared with households prior to the initiation of the installations.

The installations were followed by performance monitoring, wherein, residents were trained to fill subjective assessment forms. Objective performance monitoring was conducted over a period of 10 consecutive days, for 12 hours each day with support from residents. Additionally, 2 Critical Feedback Workshops were conducted to gather partner household members' thoughts and feedback on installations.



Figure 2.3. Critical Feedback Workshop

2.2. Insights

2.2.1. Participatory Design Workshops

- **Male and female representatives from each house (based on the family composition and decision-making culture) should be invited to participate in workshops:** Most workshops conducted were attended by women, given that men were not available at home at the time when the workshops were organised. It was observed that household decision-making processes in the settlement were rooted in patriarchy, due to which, even though the women were in favour of having the cooling prototypes installed in their homes, their decision was rejected by men in their homes. Another factor leading to this was that the women found it challenging to communicate the reason for their alignment to have the solutions installed. Therefore there were instances where the workshop team met the women's husbands/brothers to explain the design again, after which the men opened up to the possibility of having the solutions installed in their homes. This experience provided valuable insights on making arrangements to ensure that workshops are organised on days/ at times when both men and women are available to participate in workshops.
- **A safe space should be created for women to voice out their thoughts and views on the design:** During workshops where both male and female participants were present it was observed that certain women were not comfortable sharing their views, owing to our gender norms and social system. The facilitators had to make active efforts to ensure that the women felt comfortable sharing their voices by emphasising the fact that their voices are invaluable since they spend most time performing caregiving work within their homes.

- **Working models are most effective for explaining and to facilitate visualization of cooling installations for participants:** While multiple strategies including , videos, images and prototype working models, were used to explain the cooling solutions to residents, it was observed that participants shared their questions/inputs on solutions more actively when engaging with a working model of a solution.

2.2.2. Partner Household Finalizing

- **Residents who are tenants should be invited to the workshop with homeowners :** Almost 40% of the people who participated in the first round of participatory design workshop were tenants. While the tenants were willing to have the cooling solutions retrofitted to the roofs of the structures they were inhabiting, it became difficult to track their owners and communicate to each of them, with a few exhibiting resistance given that they did not understand the solutions and project as they had not attended the workshop. Therefore, a second round of household identification had to be conducted through door-to-door visit, wherein, visits were made to house structures that were inhabited by homeowners themselves. It is therefore advisable to invite both homeowners and tenants to participatory design workshops to ensure that both entities are equally aware of the cooling solutions being proposed or invite the residents who own their houses.
- **Seeking support from a resident from the community is essential to accelerate the process of rapport building and community mobilization :** After the initially shortlisted households dropped off, it was challenging for the project team to identify additional households, given that residents were skeptical of having cooling prototypes installed in their homes by an unknown entity. Therefore, the project team put efforts towards identifying a person who could support the process of rapport building with new homes. A shopkeeper who was well respected and recognised by most community members was identified and the project details were shared with him. He felt aligned to the project and supported the process of connecting the team with additional households. This accelerated the process of identifying houses and the homeowners were more open to interacting with and trusting the project team which supported the process of identifying the additional homes.

2.2.3. Fabrication And Installation

Involvement of a Community Resource Person is essential to support a smooth fabrication and installation process: Based on learnings from the household identification process the project team sought support in identifying a Community Resource Person (CRP) to support the installation process primarily from the perspective of resident coordination, logistics and conflict resolution. This was beneficial to support addressing on-ground issues such as residents being unavailable at home even after being informed about installations, difficulty with connecting to residents over the phone, conflicts in resident's understanding of the installations, making arrangements for water, ladders etc.

2.2.4. Installation Performance Monitoring

Residents were resistant to project team members visiting their houses 12 times between 10 am to 10 pm. Therefore a monitoring process that was comfortable for the resident and to ensure that temperature readings were documented as per the measurement protocol, was developed. Two insights that emerged from this process are as mentioned below :

- **Performance monitoring arrangements should be co-determined with residents to ensure a smooth monitoring process:** Based on the residents suggestion, members from the partner households themselves were identified to gather temperature from households in a given settlement area. The houses were grouped together based on their proximity and youth from one family were trained to conduct the performance measurement.
- **Both male and female volunteers should be identified for performance monitoring :** Considering that only women were present in most houses during the day, many of them were not comfortable with boys visiting their houses every hour for performance measurement. Therefore ,the project team identified and trained two girls to be part of the performance measurement process.

2.2.5. Critical Feedback Workshop

- **Feedback gathering must be approached flexibly to address residents' needs:** The Critical Feedback Workshop was facilitated in two groups at different locations. The project team evaluated and ensured the possibility of maximum participation of residents by informing them prior to the scheduled date of workshops, this helped with gaining a better understanding of peoples availability for the workshop. Two residents were at work and could not make it to the workshops and their feedback was sought over the phone and in person, respectively, to ensure that all homeowners had space to share their thoughts on the installations.
- **Gathering residents input is critical to sustain peoples trust and to inform future action in the direction of addressing the issue of heat stress in their locality :** The Critical Feedback Workshop gave community members a space to share their issues and recommendations with respect to the installations. Two households shared that they observed a crack line on the roof along the wall edge during the installation process. They were assured that their issue was noted down and would be resolved, and that the project team would work on refining the installation process in other homes in the future. The resident's feedback emanated their sense of partnership and alignment towards the entire process; they shared that they were satisfied with the way the project had unfolded. This gave way to explore future intersections and collaborative efforts in the form of Women Heat Action Cooperatives (WEHACs) as a next step towards addressing the issue of heat stress in their locality. They were aligned to learn more about it and understand ways in which they could contribute to this.

3. Cooling Solution Refinement Insights

3.1. Water Filled PET Bottles

3.1.1. Prototype Testing Refinements

PET bottle prototype testing was conducted using testbeds. Three testbeds, each measuring 4 ft × 3 ft, were prepared for comparison. A 1000 W Halogen Lamp was positioned above each test bed to simulate Solar Radiation. Temperatures were recorded hourly between 10:00 a.m. to 6:00 p.m. The temperature differences between the testbeds were analyzed to conclude which prototype works better.

The test beds were as follows :

- Testbed 1 : Business As Usual (BAU) i.e. without PET bottles. (ref figure 3.1)
- Testbed 2: PET bottles placed in roof troughs with a silapulin layer in between bottles and roof. (ref figure 3.2)
- Testbed 3 : PET bottle prototype variants. (ref figure 3.2)



Figure 3.1 BAU Testbed



Figure 3.2 Testbed (2) And (3)

Testbed 3 was refined using a combination of PET bottle arrangements and additional cooling materials, to determine the most effective PET bottle prototype version. Details of the prototypes experimented with are mentioned below.

Prototype Variants

- **Prototype 1** : PET bottles were painted with Prakritik white natural paint (ref figure 3.3), as it provided a high-emissivity and low-absorptivity (i.e. white) layer. This prototype demonstrated a reduced under-roof temperature of range 0.4 degree to 2 degree celsius.



Figure 3.3 Placing Of Pet Bottle With Prakritik White Natural Paint On Testbed



Figure 3.4 500ml Pet Bottle Coated With Prakritik White Natural Paint

- **Prototype 2** : A single layer of PET bottles were introduced in crates (ref figure 3.5). This prototype demonstrated a reduced under-roof temperature of range 0.2 to 2.2 degree Celsius.



Figure 3.5 From Left - Pet Bottle In Crates Single Layer, Double Layer, Triple Layer

- **Prototype 3:** A double layer of PET bottles were introduced in crates (ref figure 3.5). This prototype demonstrated a reduced under-roof temperature range of 0.4 to 4.2 degree Celsius.
- **Prototype 4 :** The second layer of PET bottles was placed in a staggered pattern to fill the gaps of the first (ref figure 3.6 and figure 3.7). This arrangement demonstrated a reduced under-roof temperature range of 0.3 to 0.9 degree Celsius.



Figure 3.6 Pet Bottles Placed In Staggered Pattern Inside Crate (Top View)



Figure 3.7 PET Bottles Placed In Staggered Pattern Inside Crate (Side View)

- **Prototype 5** : To introduce adequate spacing between the two layers, bamboo sticks were introduced between the first and second layer (ref figure 3.8 and figure 3.9). This was done for better heat dissipation. This arrangement demonstrated a reduced under-roof temperature range of 0.3 to 0.6 degree C.



Figure 3.8 Bamboo Sticks For Adequate Spacing Between First And Second Layer(Top View)



Figure 3.9 Bamboo Sticks For Adequate Spacing Between First And Second Layer(Side View)

- **Prototype 6** : An Alufoil sheet with the shiny surface facing downward was introduced to experiment with enhancing the effectiveness of Prototype 4 as it provided a low-emissivity surface (ref figure 3.10). This prototype demonstrated a reduced under-roof temperature range of 0.1 to 2.7 degree Celsius.

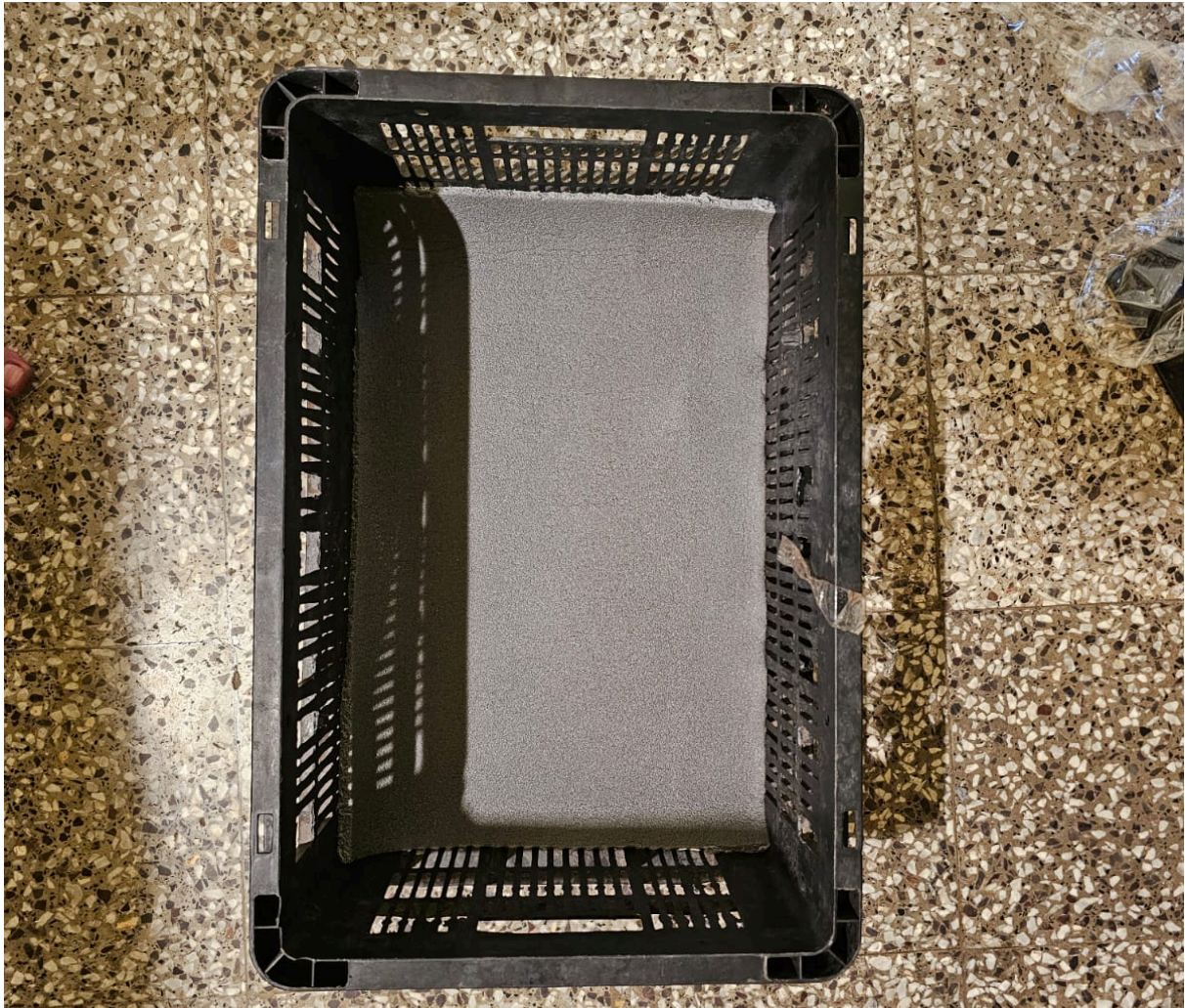

Figure 3.10 Crate With Alufoil Base

- **Prototype 7** : A Multi-Layered Plastic (MLP) sheet with the shiny surface facing downward (ref figure 3.11) was introduced to experiment with enhancing the effectiveness of prototype 4 as it also provided a low-emissivity surface. This prototype demonstrated a reduced under-roof temperature range of 0.2 to 4.8 degree Celsius.



Figure 3.11 Crate With MLP Base

Conclusion : Prototype 7 was selected for pilot installation as it performed better when compared to other prototypes

3.1.2. Pre-Fabrication Process Refinements

The initial prototype comprising PET bottles placed in roof troughs was lightweight. Given that the installation with crates would be heavier, an assessment to estimate the weight of the PET bottles with crates was conducted. According to calculation, the weight of the installation for a 100sqft house was approximately 647 kg. Therefore, the house structural audit process was refined, and a structural strength calculation tool was developed to assess a house's structural capacity to withstand the load of the installation.

3.1.3. Fabrication Process Refinements

There were no refinements in the fabrication stage.

3.1.4. Installation Process Refinements

Given that the initial prototype was light-weight, adhesives such as Heat X were used to secure the Silpaulin to the roof. Given that the crates with PET bottles were able to secure the silapulin to the roof, the usage of adhesive was reduced in the upgraded prototype.

3.1.5. Post-Installation Process Refinements

Installations were undertaken in 2 homes. Daily inspections were conducted over a 10-day period to monitor the structural response of the roofs and walls to the newly introduced load. Inspections revealed that both installations were compatible with the house structures. Hence no refinements were necessary.

3.2. Space Frame

3.2.1. Prototype Testing Refinements

- Reduction of horizontal members and subsequent pulley assembly:

Prototype 1 has a horizontal member between the legs unto which pulleys were mounted. To reduce the weight of the horizontal member, tensioned horizontal wires were installed and pulleys clipped onto it.

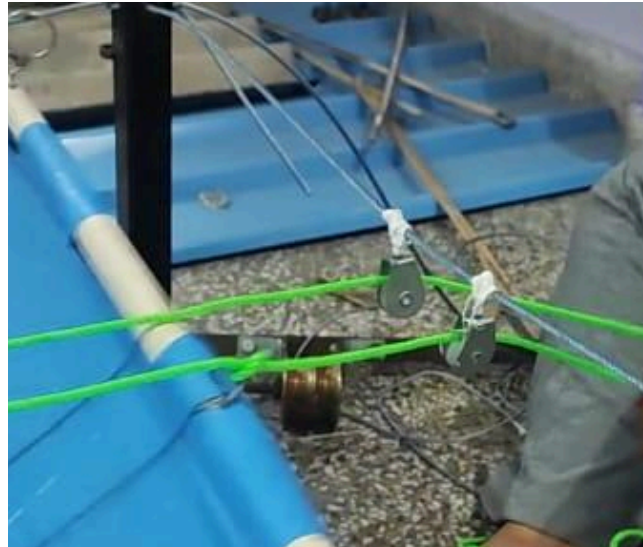
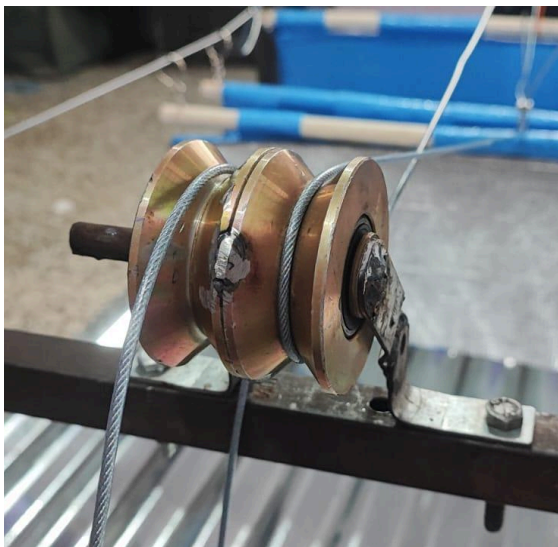

Figure 4.1 Prototype 1 On The Leftover Frame And Prototype 2 On The Right With Pulleys Clipped To Steel Wire Rope

- Clamp based supports(not commissioned for installation as it needs further testing) :

Ideating on the lines of modularity, we tested and developed clamp based support for the space frame. (See Figure 4.2)



Figure 4.2 Prototyping The Clamp-Based Support For Space Frame

3.2.2. Pre- Fabrication Process Refinements

Shift from Alufoil to Multi Layer Plastic as a Low Emissivity Barrier : Alufoil has been used previously as a market ready low emissivity barrier in previous installations, but MLP has been explored intentionally to move away from Alufoil as it is an industrial produce.



Figure 4.3 Prototype 1 With Alufoil(An Industrial Product) As Low Emissivity Barrier And Prototype 2 On The Right With Mlp Sheets For The Same Function(Made Inhouse)

3.2.3. Fabrication Process Refinements

Evolution in design of dripline: The shape of the dripline has evolved as observed. Prototype 1 has been ideated as having a larger surface area of adhesion but was failing in the basic functionality of water drainage. Hence the re-ideation of a base with a greater space for drainage.



Figure 4.4 Prototype 1 With Smaller Dripline On The Left And Prototype 2 On The Right With Wider Dripline

3.2.4. Installation Process Refinements

As issues were observed during the adhesion of base supports to the roof, additional pipe supports were added at the base to enhance the stability of the installation.



Figure 4.5 Additional Pipe Supports At The Base

3.2.5. Post-Installation Process Refinements

Installations were undertaken in 3 homes. Daily inspections were conducted over a 10-day period to monitor the structural response of the roofs and walls to the newly introduced load. Inspections revealed that both installations were compatible with the house structures. Hence no refinements were necessary.

3.3. Rooftop Gardening (Passive Irrigation)

3.3.1. Prototype Testing Refinements

- **Prototype-1**

Methodology:

A plastic bubble-top bottle was repurposed as a container, incorporating cotton wick threads and potting mix. A barrier was introduced at 1/3rd of the bottle above which was the soil and below was water with a wicking system in the middle with cotton cloth that watered the soil via capillary action. To replenish water, a pipe was inserted that jutted out starting from the bottom of the bubble-top to a few inches above the container. The pot was placed on a few bricks. Seeds of bottle gourd and beans were sown in the setup, which was observed over a period of four weeks.

Observations:

1. The wicking process was observed throughout the day. While some seeds germinated, all the cultivated plants eventually withered, except for a wild green plant that persisted.
2. Soil temperature measurements ranged between 40–48 °C, indicating that such elevated temperatures are unfavorable for the growth of the intended crops.
3. Algae growth was noticed in the water reservoir.

Conclusion: High soil temperature is a major limitation for growing the proposed plants.



Figure 5.1 Wicking Pot Made Out Of Bubble Top



Figure 5.2 After four weeks of initiation, all plants had died except heat-tolerant Wild Green

- **Prototype-2**

To address the challenge of elevated soil temperature, measures were introduced to minimize heat transfer. These included installing a barrier to reduce heat conduction from the surrounding environment to the soil and another barrier to prevent direct sunlight exposure to the water reservoir.

Methodology:

- The pot was wrapped with a jute covering, and mulch was applied over the soil surface.
- The pot was elevated from the ground to further reduce heat transfer.

Results:

Seeds germinated successfully and sustained healthy growth over four weeks, supported by regular monitoring of both the wicking process and soil temperature.



Figure 5.3 Wicking Pot Placed On A Raised Platform And Covered With A Jute Bag To Reduce Sunlight And Heat Exposure



Figure 5.4 Wicking Pot After Four Weeks Of Initiation, Showing Active Growth Of Bottle Gourd And Bean Saplings

- **Prototype-3**

Although Prototype-2 operates effectively as a standalone unit, it encounters difficulties when integrated into a multi-unit system, specifically on sloped rooftop surfaces. This is due to the need for maintaining a zero-tolerance level for slight water level variations in a multi-pot wicking system.

Even a small discrepancy in water levels can disrupt the wicking process in some pots, potentially impacting plant growth and health.

To address this issue, a float valve-supported wicking box has been incorporated into the design. This innovative solution ensures that water levels are maintained at optimal levels, even in multi-unit systems on sloped rooftop surfaces.

The float valve system has been developed and commercially validated by a farmer actively promoting rooftop gardening initiatives in Kerala. This system features a float valve mounted on the lid of the water storage container (see figure 5.5 and 5.6). A vertically inserted plastic tube containing the wicking medium is positioned beneath the growing substrate to deliver ambient moisture directly to the plant root zone. Water is supplied to these submerged containers via a pressurized drip irrigation network. The float valve mechanism automatically ceases water inflow once the reservoir reaches its designated maximum capacity, thereby maintaining optimal water levels. This design effectively minimizes water loss due to surface evaporation while simultaneously automating the

irrigation process, enhancing the water use efficiency.

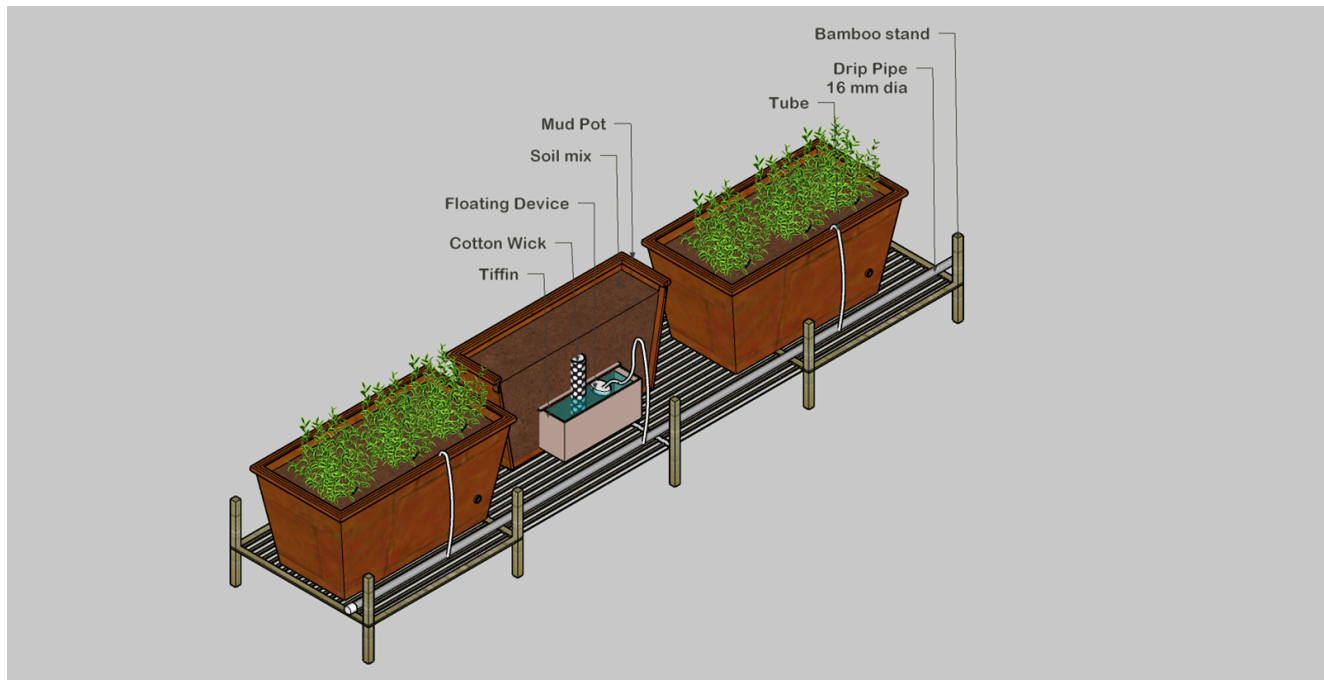

Figure 5.5 Cross section_ Float Valve Wicking Irrigation



Figure 5.6 Float Valve Wicking Irrigation

3.3.2. Pre- Fabrication Process Refinements

There were no refinements in the fabrication stage.

3.3.3. Fabrication Process Refinements

There were no refinements in the fabrication stage.

3.3.4. Installation Process Refinements

To ensure optimal water flow, use a zip tie to secure the irrigation hose in a straight line.

3.3.5. Post-Installation Process Refinements

Initially, a single float valve box was installed on a pot, however, the large size of rectangular growing pots resulted in insufficient moisture levels. To address this issue, an additional float valve box was installed in each pot.

3.4. Internal Dynamic Barrier

3.4.1. Prototype Testing Refinements

Prototype 1 of Internal Dynamic Barrier fractal measured 4ft X 3ft and was suspended on two wire ropes. There was a sag observed in the fractal both in the closing and opening position.



Figure 6.1 Prototype 1 Without Supports Forming A Bowl Shape

To counter the sag in Prototype 2, PVC pipes were introduced along the fractal at two feet intervals. This countered the sag, but increased the effective weight of the fractal.



Figure 6.2 Prototype 2 With Intermediary Supports

To arrive at the most effective number of Multi-Layer Plastic (MLP) layers used as Low Emissivity Barriers taking into consideration the factor of weight was important. The reduction in emissivity was tested where different number of MLP layers (Two, Four and Six) were placed and compared amongst each other. With the exercise described, we were able to arrive at the conclusion of using four MLP layers.

3.4.2. Pre- Fabrication Process Refinements

To reduce the weight of the fractal as well as to contain the sag in the fractal, it was decided to introduce a third support (steel wire rope) in the middle

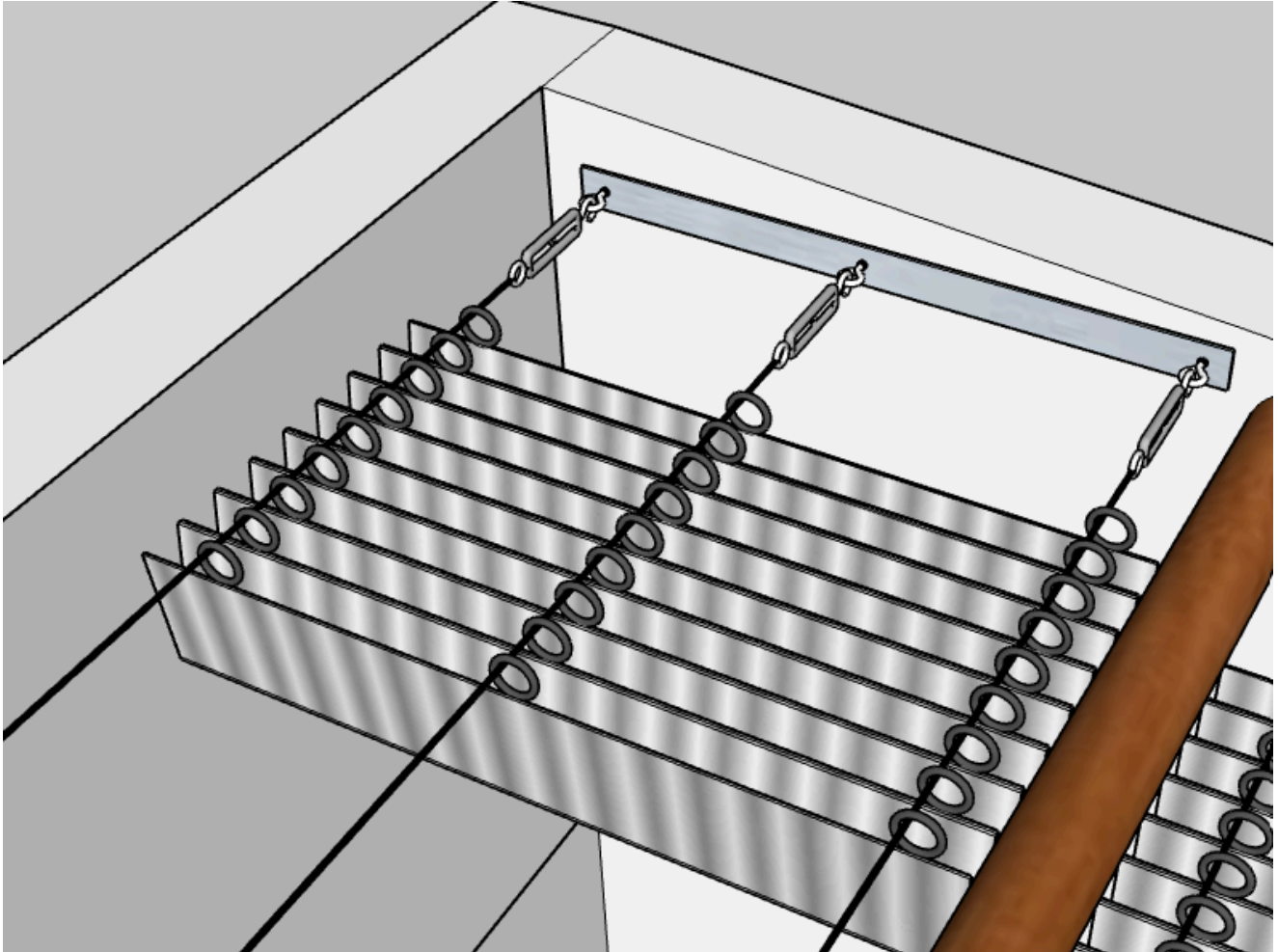

Figure 6.3 Current Installation Without Intermediate Supports And Introduction Of Third Steel Cable

3.4.3. Fabrication Process Refinements

In one of the houses where the roof height was pretty low, handling mechanism wasn't provided. The opening and retraction of Dynamic Barrier was done by hand. Instead of introducing a pipe at the rear end, the rear curtain rings were tied down to the tension fastener to arrest the rear end of the fractal from moving ahead. This further reduced the effective weight of the fractal.

3.4.4. Installation Process Refinements

There were no refinements during the installation process.

3.4.5. Post-Installation Process Refinements

There were no post-installation refinements.

3.5. Vertical Cane Blind

3.5.1. Prototype Testing Refinements

An initial prototype of 4 feet in width and 10 feet in length (vertical drop) was fabricated. The size of the MLP lengthwise was kept greater by 6-8 inches than the Bamboo Blind to not hinder easy rolling and unrolling.



Figure 7.1 Prototype 1 Of Vertical Dynamic Barrier

As the MLP was adhered to Bamboo Blind only at the top and bottom of the fractal, folds were sometimes observed on the fractal. Hence a decision was taken to tack the MLP sheets to the Bamboo Blind at a grid of 1.5 feet.

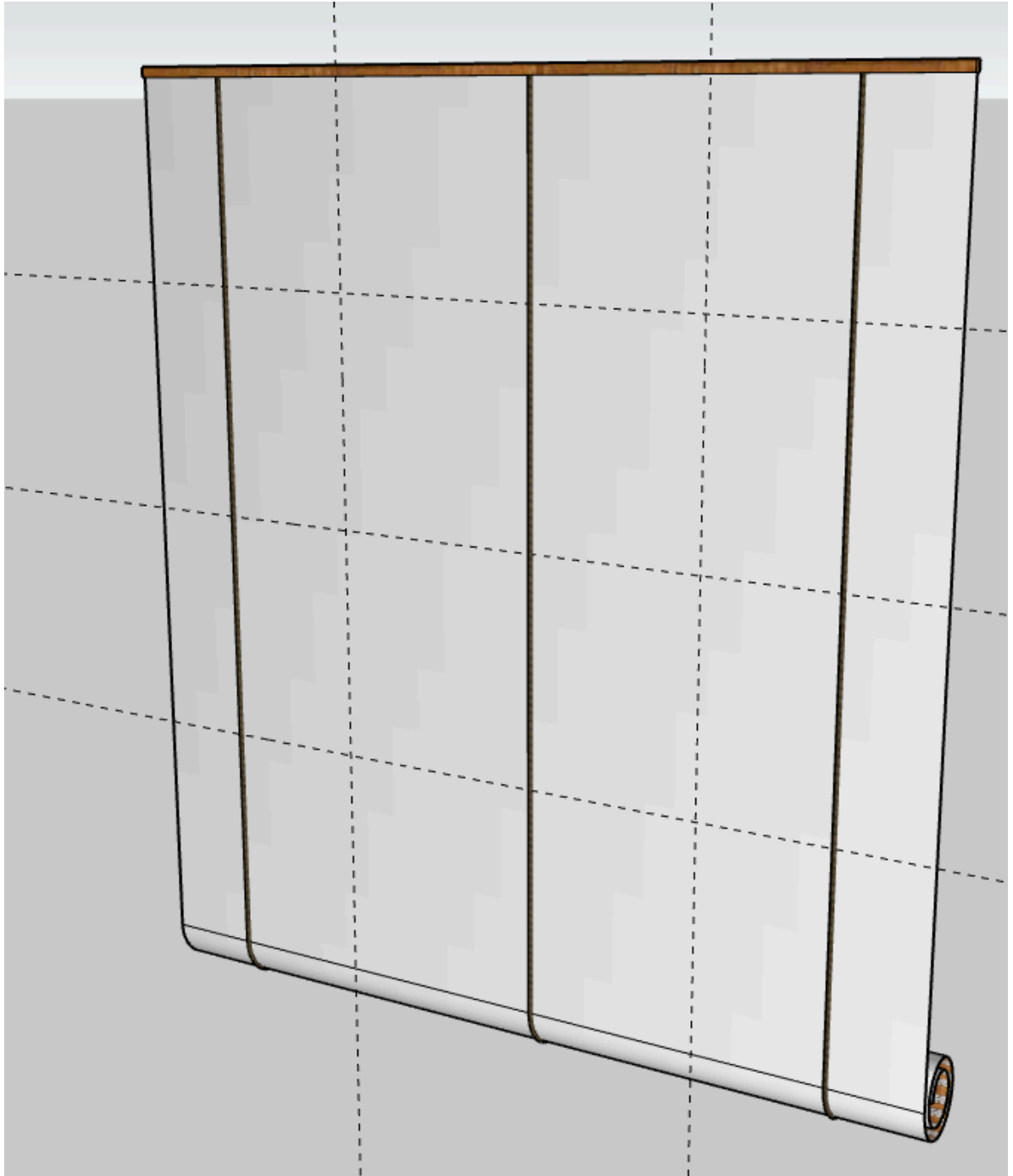

Figure 7.2 Placement Of Zip Tacks At The Intersection Of Dotted Lines Adhering Mlp To Cane Blind

3.5.2. Pre- Fabrication Process Refinements

There were no refinements in the pre-fabrication process.

3.5.3. Fabrication Process Refinements

- The Bamboo Blinds were painted with waterproof wood paint to ensure a level of weatherproofing which was not performed in Prototype 1.
- For additional reinforcement during adhering MLP sheets to the Bamboo blind, zip ties have been used at both the shorter ends.

3.5.4. Installation Process Refinements

Instead of fixing the primary bamboo member into the hook, Galvanised Iron wires were used to tie the topmost bamboo member to the supports established.

3.5.5. Post-Installation Process Refinements

There were no refinements in the post-installation process.

3.6. Biomass Panel

3.6.1. Prototype Testing Refinements

Biomass panel prototype testing was conducted using testbeds. Two testbeds, each measuring 7inch × 7inch × 7inch, were prepared for comparison. A 500 W Halogen Lamp was positioned above both testbeds to simulate Solar Radiation. Temperatures were recorded hourly between 10:00 a.m. to 6:00 p.m. The temperature differences between the testbeds were analyzed to conclude which prototype works better.

- Test bed 1 : Business As Usual (BAU) i.e. without any panels. (ref figure 8.1)
- Test bed 2 : Testbed with Biomass Panel. (ref figure 8.2).

Since the biomass panel is an underroof solution they were placed inside the respective testbed, about 1.5 inches below the GI sheet. (ref figure 8.2)



Figure 8.1 BAU Testbed



Figure 8.2 Biomass Panel Testbed (Top View Without GI Sheet)

Conclusion : Testbed with biomass panels demonstrated better cooling with a reduced temperature of 0.2 to 6.9 degree C when compared to BAU testbed.

3.6.2. Pre- Fabrication Process Refinements

There were no pre-fabrication process refinements.

3.6.3. Fabrication Process Refinements

To waterproof the biomass panels it was covered with Multi-Layer Plastic (MLP) sheets. It was covered such that the shiny side of the MLP sheets were oriented outwards on both sides. (ref figure 8.3)



Figure 8.3 Biomass Panel Draped With MLP

3.6.4. Installation Process Refinements

There were no refinements in the installation process of the design.

3.6.5. Post-Installation Process Refinements

Installations were undertaken in two households. Daily inspections were conducted over a 7-day period to monitor the structural response of walls to the newly introduced load. Inspections revealed that both installations were compatible with the house structures. Hence no refinements were necessary.

3.7. Wood Wool Panel

3.7.1. Prototype Testing Refinements

Wood Wool panel prototype testing was conducted using testbeds. Two testbeds, each measuring 7inch × 7inch × 7inch, were prepared for comparison. A 500 W Halogen Lamp was positioned above both test beds to simulate Solar Radiation. Temperatures were recorded hourly between 10:00 a.m. to 6:00 p.m. The temperature differences between the testbeds were analyzed to conclude which prototype works better.

Test bed 1 : Business As Usual (BAU) i.e. without any panels (ref figure 9.1)
Test bed 2 : Testbed with Wood Wool panel (ref figure 9.2).

Since the Wood Wool panel is an underroof solution the panel was placed inside the respective testbed, about 1.5 inches below the GI sheet (ref figure 9.2).

Conclusion

Testbed with Wood Wool panel demonstrated a reduced temperature range of 0.1 to 6.2 degree C when compared to the BAU testbed. Consequently, it was decided to install Wood Wool panels in one of the households.



Figure 9.1 BAU Testbed



Figure 9.2 Wood Wool Panel Testbed (Top View Without GI Sheet Covering)

3.7.2. Pre- Fabrication Process Refinements

There were no refinements in the fabrication stage.

3.7.3. Fabrication Process Refinements

To waterproof the Wood Wool panels it was covered with Multi-Layer Plastic (MLP) sheets. It was covered such that the shiny side of the MLP sheets were oriented outwards on both sides. (ref figure 9.3)



Figure 9.3 Wrapping Wood Wool Panel With MLP

3.7.4. Installation Process Refinements

There were no refinements in the installation process of the design.

3.7.5. Post-Installation Process Refinements

Installations were undertaken in one household. Daily inspections were conducted over a 7-day period to monitor the structural response of walls to the newly introduced load. Inspections revealed that both installations were compatible with the house structures. Hence no refinements were necessary.

Informal Housing Thermal Comfort



Manual Of Practice : Community Engagement

August 2025

Table Of Contents

I. Introduction.....	3
II. Community Engagement Guidelines.....	4
III. Community Engagement Process.....	5
1. Partner With A Grassroots Non-Governmental Organisation.....	5
a. Rationale.....	5
b. Engagement Approach.....	5
2. Select Project Locality.....	6
a. Rationale.....	6
b. Engagement Approach.....	6
3. Conduct Listening Workshop.....	8
a. Rationale.....	8
b. Engagement Approach.....	8
4. Identify A Community Resource Person.....	13
a. Rationale.....	13
b. Engagement Approach.....	13
5. Participatory Design Workshop.....	14
a. Rationale.....	14
b. Engagement Approach.....	14
6. Conduct Household Selection Decision Sharing Meeting.....	18
a. Rationale.....	18
b. Engagement Approach.....	18
7. Sign Partnership Agreement.....	20
a. Rationale.....	20
b. Engagement Approach.....	20
8. Conduct Thermal Comfort Assessment Form Training.....	22
a. Rationale.....	22
b. Engagement Approach.....	22
9. Organise A Resident Experience Tour.....	24
a. Rationale.....	24
b. Engagement Approach.....	24
10. Conduct Resident Critical Feedback Workshop.....	28
a. Rationale.....	28
b. Engagement Approach.....	29
IV. Annexure.....	32

I. Introduction

Sleepless summer nights, unbearable daytime temperatures inhibiting household activities, health conditions such as nausea, headaches, heart palpitations and dizziness, are few of the many heat stress related issues plaguing the lives of people from marginalised urban settlements. While people in affluent homes seek thermal comfort through climate-polluting and energy-intensive technologies such as airconditioners (a typical 1-ton split-AC in India consumes as much power as 25 ceiling fans) especially during peak summers, the marginalised often live in cramped, poorly ventilated houses with scant protection from solar heat. Additionally, the affluent often possess backup power sources (diesel generators etc.) to permit constant energy use during planned power-cuts induced by the high-demand of energy for indoor cooling, while the urban poor are unable to even operate a ceiling or floor fan (ventilator) to maintain a modicum of comfort during peak summers, increasing their vulnerability to thermal distress. Women in particular are disproportionately impacted by heat, given that they culturally shoulder a greater proportion of family caregiving work, which requires them to wake up earlier than other members and also spend more time indoors to perform household chores such as cooking and cleaning. Given the prevailing climate crisis, temperatures are bound to increase in the coming years. Therefore to alleviate energy burdens and provide affordable indoor cooling to people from marginalised homes, there is a need to resort to retrofitting homes with passive cooling solutions that provide thermal comfort with minimal energy usage.

Given that India's demographic and spatial and socio-economic landscape is dynamic and varied, addressing heat stress through passive cooling warrants resorting to a diversity of solutions as opposed to following a one-size-fit all implementation strategy. For instance, a widely recognized solution is having high reflectance (through coating roofs with white paint) as a singular strategy of cooling the roof, however, this poses severe limitations of maintenance as it needs to be exposed to sun and not covered or hampered through activities, especially in low-income settlements, where the roofs are used for a plurality of purposes and quite often covered with plastic sheets. It is therefore vital to ensure that cooling solutions are sensitive to the socio-ecological and climatic context in the place of implementation; this can be achieved only in consultation 'with' local communities.

This 'Manual of Practice' is aimed at guiding organisations/institutions aligned towards working on addressing the issue of heat stress 'with' communities inhabiting informal settlements. The first part of the manual highlights overarching community engagement guidelines and principles to inform community engagements. The next section titled 'Community Engagement Process' shares steps recommended to ensure that thermal comfort retrofit installations are undertaken in consultation with communities to ensure that the solutions are sensitive to the socio-economic, ecological and climatic context of households. This section details the rationale and approach to engagement supported by questionnaires, workshop designs and other elements, as applicable. These components are placed in boxes in the manual.

Please note that the 'Engagement Approaches' shared in this manual are not hardbound and can and must be tweaked to suit different contexts. For e.g. if your organisation already has a well established bond with grassroots communities inhabiting the locality you aim to work in, you need not collaborate with a grassroots NGO partner.

II. Community Engagement Guidelines

Following are a few community engagement guidelines that are applicable across all community interactions :

1. Objectives of the project should be the primary guideline for engagement.
2. The interests of the community should be top most priority.
3. Strictly define areas of intervention and non-intervention.
4. Consent and transparency:
 - Seek consent before speaking, documenting discussions (in any form), etc with community members.
 - Be transparent about how/where information that will be documented as part of listening sessions, other interactions will be shared.
 - Be clear about our reasons for wanting to work with the community, what we are hoping to offer and our approach at working towards it.
 - Let the community know that we want to work 'with' and 'not for' them.
5. Empathetic interaction: Speak and interact with the community, the way you'd like people to speak and interact with you. Place yourself in the shoes/slippers/sandals,etc of the people you interact with. Be respectful, honest and kind.
6. Stay grounded: Sit with the community, eat what they offer you (if you cannot- decline politely), preferably wear garments that resonate with the community.
7. Build a rapport with the community: Recognize that we are engaging with the community to build a relationship with them and work together. We are not there as just data collectors! Besides, good rapport can support meaningful and authentic conversations.
8. Have a community led discussion: In all interactions create a space where community members recognize themselves as knowing more than we do (which they obviously do!) about their situation. Besides intermittent prompts, let the community lead conversations. Use symbols, illustrations and other means of communication to facilitate discussion with members who might not be literate. Convey that no one else is better suited to discuss their situation and decide what they need and do not need. (As a facilitator: Listen more, speak less)
9. Non-intrusive documentation: Non-intrusive documentation is essential to avoid disrupting authentic conversations. (options - taking notes, audio recordings etc, with community consent)
10. Respect : Respect community member's boundaries (time, privacy, topics they express discomfort with, etc.), opinions, and culture.
11. Patience: Sessions might be delayed, community members might have quite a few questions for you, community members might express scepticism, etc. Be patient with them and yourselves as you embark on the journey of knowing each other.
12. Create an empathetic and safe listening space: Pay attention to non-verbal cues by community members that hint at discomfort, etc. and address the situation accordingly. Create a space where community members feel comfortable discussing themselves and their lives/people in their lives. A space where there is no feeling of privacy invasion or being forced to speak. A space where anyone feels free to walk away from the space if they want to without feeling obliged to sit, speak, and interact with you.
13. Humility: Acknowledge your privileges and viewpoints that emerge from your position. Recognize that as an outsider, you know a fragment about community members and their journeys. Be humble

enough to recognize the things you might not know/understand and seek clarity from the community about the same.

14. Be willing to unlearn: Let go of the socio-cultural, academic, experiential baggage you come with, when you engage with the community. Every person /community has different stories to share that need to be acknowledged and not subjected to our baggage. As far as possible, prevent your baggage from influencing your facilitation.
15. Speak from personal experience/ I: Encourage participants and yourselves to take responsibility for your experiences. Eg. Replace 'he/she did' ...with 'I felt --- when--- happened', etc.

III. Community Engagement Process

The process detailed under this section is recommended to ensure that community knowledge is harnessed and community consent sought throughout the process of engaging with a community that is being offered passive cooling installations as part of the 'Informal Housing Thermal Comfort' mission, for the first time (for examples of passive cooling solutions, refer to the 'Solutions Summary' section on [this](#) webpage) .

All engagement steps mentioned before the 'Resident Experience Tour'' are to be conducted before commencing fabrication and installation of cooling solutions. The engagement related to 'Thermal Comfort Assessment Form Training' is vital when experimenting with new installations whose effectiveness may have not been field tested before.

The 'Critical Feedback Workshop' and 'Resident Experiment Tour' are relevant to gather community members observations and feedback on the first set of installations in a new community and to inform future efforts aimed at ensuring the sustenance of thermal comfort retrofit services in the settlement.

1. Partner With A Grassroots Non-Governmental Organisation

a. Rationale

- i. To collaborate with grassroots NGOs partners to help facilitate rapport building with local communities in project locations

b. Engagement Approach

- i. Identify grassroots NGOs working in your project city through existing networks or online research
- ii. Narrow down on NGOs based on the work they are engaged in (preferably those engaged in the realm of informal housing upgrades)
- iii. Explore the NGOs values and approach of interacting with the community and their relationship with the community to check if it resonates with your projects engagement approach (eg. Do they consider the community as partners, do they respect and harness the communities' knowledge? Do they have authentic relationships of trust with the community? Or do they impose solutions and disregard the communities' knowledge and experience?)
- iv. Reach out to NGOs that align the most with your projects values and approach
- v. Share details about the 'Why', 'How' and 'What' of your project and inquire if they would be interested in exploring ways to work with you.

- vi. If the NGO expresses interest in engaging with your organisation, set up a meeting and 'listen' to the NGOs 'Why','How', and 'What' of working with the stakeholders they engage with.
- vii. Explore ways to engage meaningfully with the community, through meaningful and respectful exchange of ideas with the partner NGO
- viii. If the NGOs work and approach to working resonates with the overall approach of the project, proceed to:
 - a. Discuss the project duration
 - b. Share and agree upon specific areas of the project where the NGO partners support will be needed
 - c. Share and agree upon the roles and responsibilities of the NGO partner and the project team
 - d. Share and agree upon the effort hour contribution that is feasible based on the project funding capacity
- ix. Draft a 'Partnership Agreement' with the above-mentioned and other relevant information.
- x. Share a signed copy of the partnership agreement with the NGO partner for their signature.

2. Select Project Locality

a. Rationale

- i. To identify an informal housing locality that is suitable for and needs intervention from a thermal comfort perspective.

b. Engagement Approach

- i. Make a list of locality selection criteria, including but not limited to the following:
 - a. NGO partner has a presence in the community
 - b. Vulnerable to heat stress/adjacent to heat-generating industries/ factories/ any economic activity
 - c. House structures in the community are primarily built with heat trapping materials
 - d. A tenure protected informal settlement
 - e. Locality will not be affected by large scale infrastructure projects in the near future.
 - f. Has members engaging in home-based work
 - g. Locality has some history of participation either with NGO partner or the community is proactive in solving its own problems
- ii. Draft a questionnaire based on locality selection criteria.
- iii. Visit the locality and seek support from the local NGO partner to populate responses to the questionnaire.

The following questionnaire can be used as a basis for locality selection :

Questionnaire - Locality Selection

Field Visit no:

Date of visit:

Location (City):

Settlement name:

GPS Coordinates(Optional):

NGO representative details (Name, contact no):

Project team member name:

*Note for field team:

Kindly click photographs of:

1. House structures
2. Location geography (open spaces, green cover, waterbodies, etc.) - *[in case this is not possible, navigate the same on google earth, based on GPS coordinates.]*
3. Other notable aspects, based on your judgement.

Place your photographs based on the template in the following folder: ---(add relevant Gdrive/folder location details)

Kindly upload interview responses to the following file ---(add relevant file details)

Questions:

Social Attributes :

1. What is the duration of the NGO partner's relationship with the community?
2. How many households does the settlement comprise?
3. What is the population of the settlement?
4. Do the households belong to a particular caste, religion, work group or is it a mixed community?
5. What diverse occupations are community members engaged in?
6. Are there community members who are engaged in home-based work? (approx. how many households)
7. Are there community members who migrate to other cities/states for work?
8. What is/are the driving factor(s) for migration to other cities/states?
9. What type of work do they engage in the places of migration?
10. Is there a presence of any local microfinance institutions/other lending institutions in the settlement?
11. If yes, what are the names of these institutions?
12. Does the community have a history of being proactive in solving their problems?
13. Is the settlement tenure protected? (can also check city development plan)

14. Are there any infrastructure projects planned in this location in the future that might demand resettlement/rehabilitation?
15. If yes, what is the nature of the project/s that is/ are planned? (eg. road, railway, etc)
16. When is/are the project(s) planned to be initiated?
17. How is the relationship between the community and local politicians? (prompts: has there been a history of prolonged resistance, etc or are issues resolved collectively)
18. Are there any existing community groups/associations in the settlement? If yes, what issues do they work on and who is part of these groups?
19. Is heat stress an issue residents are concerned about? (based on NGO partners' judgement)
20. If yes, what are these claims based on?
21. Would you recommend engaging with local politicians before initiating project work?
22. Miscellaneous details

Physical attributes (Can be noted during field visits/in conversation with NGO partner):

1. Distance of the settlement from field members home (in km)
2. Does the settlement design indicate a lack of daylight/ventilation? (*can substantiate this with photographs, if possible*)
3. Are there any notable factors indicating that the locality is vulnerable to heat stress? (eg. adjacent to heat-generating industries/ factories/ any economic activity)
4. What are the house structures in the settlement? (a healthy mix of house structures is preferable)
 - a. Semi Kuccha - Tin Roof And Tin Walls
 - b. Semi Pucca - Brick Wall And Tin Roof
 - c. Pucca - Brick Wall And Concrete Slab
 - d. Others (Please Specify)
5. Are houses in the community primarily built with heat trapping materials? (e.g. asbestos roofs,etc.)
6. Are there any community spaces (eg. Balwadi centres, community hall, etc) that could serve as spaces for pilot prototype implementation/installation?
7. Miscellaneous details.

3. Conduct Listening Workshop

a. Rationale

- i. To create a space for people inhabiting informal settlements to share their experiences on issues they face across different seasons during the year.
- ii. To understand already existing heat battling mechanisms and practices followed by the communities.
- iii. To listen to community's discomforts, concerns and suggestions
- iv. To emphasize the projects approach of 'co-creation' and 'participatory' action to community members to facilitate a spirit of 'partnership' and 'collaboration'

b. Engagement Approach

- i. Identify a place and time that is convenient to interact and facilitate listening workshops with the community in consultation with the NGO partner.

- ii. Seek NGO partners support to invite community members to the workshop and check if the suggested day and time works for them.
- iii. Details of the workshop design and roles and responsibilities of team members are mentioned below.

A. Facilitation team roles and no. of members :

- Documentation persons (note taking, audio recording, photography): 2
- Facilitators: 2-3
- Community mobilization persons (NGO field team members): 1-2

B. Material:

Charts with symbols (1), sketch pen set (1), pencils, erasers, book for note taking, pen, audio recording device (phone), post-its, refreshments, garbage bags.

C. Setting & Participants:

Community space, rugs/mats or chairs that can be moved. (Community members and facilitators sitting on the floor in a circle. Elders, people with health conditions who are unable to sit on the floor sit at elevated positions and are part of the circle too.)

D. Workshop Flow (max. 2 hours):

1. Group introductions & ice-breaker (10 mins):

All members go round the room sharing their name, where they are from/ since how long they've been living in the settlement and what is one of their favourite activity to engage in during the day/the place they live in etc (any prompt to help participants connect with each other/break the ice with each other).

(*Any other activity the facilitator finds suitable to support participants to connect with each other can be used too.)

2. Introduction, consent and setting the tone (20 mins)

- a) Introduce your organisation and what you work on.
- b) State how you got to know about the community, your relationship with the partner NGO and community members who you may have met before (and will support in facilitating the session.)
- c) Explain why you are here:

- Share your project story
- Purpose of the listening session:

(Suggested script: We have experience in the domain of thermal comfort, however, we want to understand your perspective and know if this is an issue you experience and would like to work towards resolving. We want to hear from you and understand your situation before we explore possibilities of collaborating to address thermal comfort and other related issues. You are the leaders and we will just facilitate this session. The purpose of this session therefore is for us to learn from you and understand your situation, since nobody knows your needs better than you.)

- d) Give the community space to ask questions / suggestions they might have for the session- (A space to co-create principles for the session- eg. phones off, one person speaks at a time, etc)
- e) Seek consent for documentation. (It is advisable to avoid photos/videos during the first workshop to encourage authentic participation)
- f) Create a safe space i.e. Ensure that community members feel safe, comfortable and own the space: Give them the option to speak in the group discussion, speak to anyone from our team after the discussion, share thoughts in any other form that is comfortable.

3. Problem Diagnosis: Illustrating and listening (40 mins)

*Note for the facilitator: For this section - after you ask a question be mindful about giving participants enough time to digest the question before they respond. If you feel the need to prompt participants after leaving enough time for them to reflect and respond to your question, you can give examples of information that was shared by people in past workshops in other locations which might catalyze participants to reflect on their own experiences and share them with the group. During the session keep reminding participants that they are most knowledgeable of their context since they live there and therefore it will be helpful for them to share their perspective authentically without any fear of judgement.

Suggested text:

A. *We will begin by exploring your experience in this space across different seasons. We can begin with the season that you think is the most uncomfortable for you during the year.*

1. *What is the most uncomfortable season/time of the year for all of you? (eg. Summer, Winter ,Monsoon)*

1.1 *What is the most uncomfortable time during this particular season?*

- *Morning*
- *Afternoon*
- *Evening*
- *Night*

1.2. *What is the cause of this discomfort? (prompts, if needed : eg. unable to focus on work, unable to sleep, etc...it will also help if you can think and share what things are like for your children, the elderly, people who are sick, and others you know of.)*

The facilitator can ask each participant to share their thoughts one after the other as another person from the facilitation team makes notes of the issues on a chart paper which has illustrations of the seasons being explored (ref image below), alternatively post-its can be shared with participants and the facilitation team can support them in writing/illustrating their thoughts on post-its.



2. What is the second most uncomfortable season during the year?

2.1. What is the most uncomfortable time during this particular season?

- Morning
- Afternoon
- Evening
- Night

2.2. What is the cause of this discomfort? (prompts, if needed : eg. are you unable to focus on work, unable to sleep, etc. it will also help if you can think and share what things are like for your children, the elderly, people who are sick, and others you know of..) It is okay if the issues repeat/overlap across the seasons.

Leave space for participants to share their thoughts as another person from the facilitation team makes notes of the issues on the chart paper or supports people in writing/illustrating issues they experience during the particular season/time of the year.

3. Let's move on to the final and most comfortable season.

3.1. Is there anything that you wanted to share about this season in terms of discomfort you face? (the subsections of this part can be skipped if people indicate that they have nothing to share here)

3.2. *What is the cause of this discomfort? (prompts,if needed : eg. unable to focus on work, unable to sleep, etc. it will also help if you can think and share what things are like for your children, the elderly, people who are sick, and others you know of.). It is okay if the issues repeat/overlap across the seasons.*

B. *Thank you for sharing your experience across different seasons. This is helping us understand your context better. We would like to explore a few key building structure-related issues you have mentioned so far that you'll might be already addressing . This will help us understand your experience better which will be helpful as we work on solutions in the future. (Identify structure-related issues such as heat stress and water leakage, etc from the chart and start exploring each issue in detail) - 10 mins*

1. *How have you worked on addressing these issues? (prompt for heat stress and monsoon related issues: Do you have any existing mechanisms in place to address heat/monsoon-related issues? If yes, what are they? How effective is this remedy you use to tackle heat/monsoon stress? Does it cool the temperature inside during summer/reduce your problems during the monsoon and for how long?]*
2. *Who are the people that are involved in addressing these issues?*
3. *What are the challenges you/other members face as you go about addressing issues? and how do you overcome them? (eg. Stakeholders who support them, hinder them, etc)*
4. *Are there any governance mechanisms in place to help you address issues?*

4. Project overview, discussion and closing (15 minutes)

4.1. Project overview and discussion (10)

Suggested text to link the previous section to this one: *Thank you for sharing your experiences across different seasons with us and also for sharing your knowledge on the practices you follow to address certain issues within your capacity. As mentioned at the start, the project we are working on aims at working towards reducing heat stress and addressing related structural issues across other seasons, too. We, therefore, have a few questions for you before we share the next steps of the project and wrap up this workshop.*

1. *Based on your sharing it seems like the summer/monsoon/winter season is the time during which you experience most issues which need attention. Is my understanding correct? Or do you have other thoughts on this?*
2. *If more than one season is difficult for the participants the facilitator should confirm - from what you shared about your experience earlier do you feel that along with heatstress/monsoon/winter season related issues we need to work towards addressing summer/monsoon/winter related issues too? (eg. address leakage issues with heat stress issues)?*

Thank you for sharing your thoughts on this. We will now give you an understanding of the processes that will follow after this workshop if you would like to continue working with us.

3. Explain the project engagement process :

- Overview of project activities with timelines e.g. structural audit, participatory design workshop, fabrication and installation, monitoring by residents and the project team, use and maintenance phase feedback phase, etc..
- Roles, requirements, responsibilities of participants (participate in workshops, support with monitoring, share feedback, be accommodative to occasional visitors who will visit the house to see the installation and to learn about it - after giving residents prior notice of the visit)
- Roles and responsibilities of the project team.
- 4. *What are your thoughts and feedback on what you've heard about the project? Any questions you have?*
- 5. *Would you be able to contribute, be part of this process and commit this time/energy?*
- 6. *What has been your experience with previous such projects? What are your concerns? Even judgments? Hopes? What needs are important to you in the process? What should we keep in mind as we work with you to ensure that we work in a way that is respectful to your needs?*

5. Closing (5 mins)

What else do you want to share with the group? How are you feeling about all this? What are you leaving with?

Thank you for your time :)

4. Identify A Community Resource Person

- a. Rationale
 - i. To identify a community representative who can support coordinating on-ground engagements with the community members.
- b. Engagement Approach
 - i. Develop criteria for identification of a Community Resource Person (CRP). The criteria can comprise but need not be limited to the following:
 - A person who is aligned with the mission of addressing the issue of heat stress in their local community.
 - A person who is not likely to move to another locality over the coming 2 years (minimum)
 - A person who exhibits leadership qualities.
 - A woman (preferable), who can be instrumental in stewarding future action in the direction of establishing a Women Heat Action Cooperative (WEHAC) in the area.
 - ii. Determine a monthly stipend for the CRP based on anticipated roles and responsibilities each month.
 - iii. Draft a MOU with roles and responsibilities, duration of engagement and monthly stipend details.
 - iv. Work on identifying potential CRPs with NGO partner.

- v. Meet with potential CRP(s).
- vi. Formalize engagement with the resident(s) willing to play the role of a CRP.

5. Participatory Design Workshop

- a. Rationale
 - i. To harness information to inform the contextualization of thermal comfort solution designs with local communities.
- b. Engagement Approach
 - i. Identify a place and time that is convenient to interact and facilitate the participatory design workshop with community members with support from the NGO partner.
 - ii. Seek the NGO partners support to Invite community members to the workshop and check if the suggested day and time works for them.

Details of role, responsibilities and workshop design are mentioned in the box below.

- A. **Participants:** 6 community members (max).
- B. **Workshop Team Roles and Responsibilities :**
 - 1 notetaker
 - 1 facilitator
 - 1 team member to explain the models (preferable and advisable to avoid taxing one speaker i.e. the primary facilitator) OR 1 person to support the facilitator in cases where there is only one facilitator and note taker from the workshop team, an NGO partner team member/CRP can be asked to come onboard for support with setting up the models and arranging them as needed during the workshop. If there is a team member to explain models apart from the primary facilitator the arrangement of the models can be managed by the two.
- C. **Requirements:**
 - Space enough to accommodate all participants, working models and workshop team members in a single room.
 - Materials: Workshop flow document and Cooling Solution Description Sheet (see Annexure), cooling solution working models, note taking book, pen, audio recording device (phone, etc).
 - Other arrangements: Water, toilet, handwash, snacks & beverage, lunch, garbage bag, plates, glasses
 - Facilitator to orient themselves to the previous listening workshop notes.
 - Team member to support working model arrangement oriented to flow of the workshop and support needed by him/her during the workshop.

D. Workshop flow (Time: Approx. 2 hours)

1. Introduction and explaining the workshop flow (10 mins)

- Workshop team and community members share their names and what they do (if there are new members present since the Listening Workshop) and how they are feeling.
- Thank community members for sharing their insights during the Listening Workshop
- Share a recap of learnings related to seasonal distress from the workshop, including community knowledge harnessed and any visuals of that to establish the reason for having a participatory design workshop with the community.
- Ask community members if they have any more ideas/thoughts to share.
- Share prototype ideas with the community : *We will introduce a few options to address issues of thermal comfort, which might also address water tightness, etc. These are just suggestions and through this engagement we are hoping to refine these/ eliminate options you think might not work, so that we can determine solutions that can be installed in your homes. Please keep in mind, we want to explore contextually appropriate solutions and determine suitable solutions in consultation with you. You are experts of your homes, your needs, and resources available and your thoughts and inputs are invaluable .This is all part of an exploration to discover what is possible. Any new ideas may be used as part of future prototype designs if we are unable to accommodate all ideas at this point.*
- Leave space for questions/comments.
- Seek consent to click photographs, take notes, record videos.

2. Explaining models and brainstorming (15 mins per model) - 1 hour 10 mins

(Note - It is advisable to take a short break in between the brainstorming session based on sensing the energy of the group to allow for some body movement and avoid sitting at a stretch for a long time)

- Place the model which is being explored at the centre of the room, preferably at a distance which is accessible for community members to touch the mode.

(Continued on next page)



- Follow the following sub steps for each model :
 - a. Make space for residents to reflect and share their initial thoughts about the model.

**Note for workshop team members - Pause to let residents think and share what they feel about the proposed design. You can ask them how they think the installation will support cooling (go around the room and give residents space to pass their turn to speak to another resident if they need some more time to think. Come back to them later)*
 - b. Share the name of the prototype.

**Note for workshop team members- Ensure that you break the name of the prototype down into parts and pronounce it slowly. You can also translate the name of the prototype into the local language whenever possible e.g. Rooftop Garden, Water Filled PET Bottles.*
 - c. Explain the working principle of the material and design description of the proposed prototype (as applicable) :

**Note for workshop team members- Use relatable examples to explain this eg. to explain how Multi-Layered Plastic functions we can explain how it works as a cap creating a barrier between the sun and the person inside the house. You can also make use of the material you may have carried with you to share a more realistic description of the material and design with the community.*
 - d. Make space for initial questions by residents
 - e. Make space for residents to share their concerns with the model and note them down (Prompt : What are the issues you think you might experience due to this material/the installation? Issues you might experience across different seasons?)

**Note for workshop team members - Please note that your role as facilitators/co-designers is not to defend the models when questions are posed in relation to our design. Your role is to listen and be curious about people's reasons for questioning the design. It will be beneficial for us to have a 'why do you think so?' approach as opposed to a 'no...but' approach. It is also equally important for people to know that you are making a note of their concerns, therefore make sure to say 'thank you for sharing your thoughts on this, we have made a note of this and our team will consider your inputs while refining/finalizing the design'.*

- f. Make space for participants to share their ideas on how they think we can resolve certain issues they observe with the models.
- g. Ask participants if they have any other suggestions etc in place of the suggested prototype design. (eg any other material, operating model etc)
- h. Ask participants if they would prefer to have the prototype installed in their house.
- Make space for any final thoughts on the proposed designs (Any Questions/Concerns/ Suggestions?)

3. Way Forward (10 mins)

- Next steps :

Explain the next steps and approx. dates for the next engagement with the community :

1. Learnings from the Participatory Design Workshop will be absorbed and designs will be contextualised, as required.
 2. A community meeting will be conducted (approx dates) :
 - To share refined prototype ideas.
 - To share list of shortlisted partner households
 - To share reasons for shortlisting the selected households.
 3. Fabrication and Installation will be undertaken in selected homes (approx. dates)
 4. Training for Subjective Thermal Comfort Monitoring will be conducted with partner households (approx dates)
 5. Experience tour will be conducted to gather neighboring residents thoughts and feedback on all installations (approx dates)
 6. Critical feedback workshops will be conducted to gather homeowner feedback (approx dates)
- Revisit roles and responsibilities of households who decide to embark on the journey, as shared during listening workshop:
 1. To participate in workshops
 2. To support with monitoring
 3. To share feedback on installations

4. To be accommodative of occasional visitors who will visit the house to see the installation and to learn about it (after giving residents prior notice of the visit)
- Revisit roles and responsibilities of project team/NGO partner :
 1. To be available to respond to residents queries and concerns.
 2. To give residents prior notice in case of any activity being conducted.
 3. To pay for installation costs.
 - Make space for questions by participants.
 - Ask who is interested to be part of the installations.

4. Wrapping up (5 mins) :

- Make space for any final questions
- Ask participants to share a few words on what they are feeling
- Thank participants for showing up .

6. Conduct Household Selection Decision Sharing Meeting

a. Rationale

- i. To share refined prototype ideas with community members after house audits.
- ii. To share reasons/criteria for prioritizing certain households as experiment partners
- iii. To share residents' responsibilities (eg. thermal comfort assessment, etc), next steps of the project

b. Engagement Approach

- i. Conduct house audits.
- ii. Work on household selection criteria, that can include but need not be limited to :
 - Structural feasibility of a household for a particular design
 - Houses with poor conditions
 - Age of the structure (old houses are preferable)
 - Residents preference
 - Residents with a unique prototype preference
 - Other social characteristic based criteria (wherever applicable)
- iii. Identify a place and time that is convenient to interact and facilitate the meeting with community members, in consultation with NGO partners.
- iv. Conduct the meeting.

Details of role, responsibilities and meeting design are mentioned below.

(Please note: While the description and information below encapsulates all elements that can planned for the meeting, elements should be tweaked and/or eliminated based on the need of the hour)

Option 1: Large Group Meeting (45 mins)

A. Facilitation team roles and no. of members

- Documentation persons (note taking, audio recording, photography): 2
- Facilitators: 2
- A design team member: 1
- Community mobilization persons (NGO field team members): 1-2

B. Material for the session:

- Images/videos of final prototype design
- Information about selection criteria, next steps and approx days/dates for next engagements.
- List of households who have been shortlisted as experiment partners

C. Meeting flow

- Welcome and appreciate everyone for their participation in the previous workshops (5 min)
- Describe prototype modifications based on suggestions, as applicable (10 min)
- Explain household selection criteria (10 min)
- Share list of shortlisted households and installations : (5 min)
- Take any concerns or comments about the installation process or prototypes (20 min)
- Next steps :
 - a. Inform selected household members that they have time (eg. 2 days) to share their agreement on having the select installations retrofitted in their homes.
 - b. Share details of agreement formalization : *If you agree, we will also give you a document saying that you are willing to partner with us which will mention the support we need from you and our responsibilities, both. Someone from our team will sign this and we'll need one of your family members to sign this as well. We'll share this in detail during our meeting on ----- (day of thermal comfort assessment meeting)*
 - c. Make it clear that if the installation doesn't work for them it will be removed
 - Make space for questions.
 - Thank everyone for showing up.

Option 2 : Household visit interaction format (20 mins/house)

Suggested text for explanation:

How have you been?

Thank you for your suggestions during the workshops, they were very helpful and our team has been working on them.

Share details of any critical design refinements, as applicable.

As discussed during our workshops we have the capacity to work only with — households. For now, we have selected — households. We selected the households based on the following criteria (Share selection criteria.

We will work on installing prototypes in --- households and will monitor them for ---- months. This will help us understand if we need to make any more modifications before proceeding to make these solution designs available to more homes.

Learnings from the homeowner's experience, our observations and your feedback as well, will help us understand if we need to modify/eliminate any prototypes. This entire process will take approximately — months from now.

Do you have any questions? concerns?

For shortlisted households : Are you willing to be part of this project journey with us?

Thank you for your time.

7. Sign Partnership Agreement

a. Rationale

- i. To seek residents consent to participate in the project in writing.
- ii. To assure the residents of the project teams responsibility towards attending to any issues that might arise due to the installation

b. Engagement Approach

- i. Draft a consent form
- ii. Identify a day and time to meet residents and share consent form details with them.
- iii. Read the form/ask residents to read the form
- iv. Check if the content of the form is agreeable to residents
- v. Fill the form details/Ask residents to fill the form details
- vi. Project team and resident to sign the form
- vii. One copy to be kept with the project team and the other to be kept with the resident

The template of the 'Partnership Agreement Form' is shared below.

Informal Housing Thermal Comfort Project

Partnership Agreement – Community Resident and cBalance

I and my family, residents of, volunteer to be part of the 'Informal Housing Thermal Comfort Project' experiment and agree to have the thermal comfort solutioninstalled as part of our house structure.

We agree to keep the installation as part of our house structure for a period of 12 months to support the monitoring process. (Fromto.....).

We also agree to have the thermal comfort sensors installed in our house for monitoring purposes during the months of We will notify the Project team incase any issues arise due to the sensor and will leave it untouched unless necessary. We will also support filling the thermal comfort assessment form during this period.

I am aware that this is an experiment. Therefore, in case there are any unforeseen damages/dangers that might emerge during the monitoring period we will request the cBalance team to remove the installed solution. After residents contact the cBalance team incase of any critical issue, cBalance will remove the solution within 2-5 days after evaluating the situation with the residents.

Since this is an experiment, the cBalance team will bear all costs associated with installation, maintenance, monitoring and removal of the thermal comfort solution for a period of 12 months fromto.....

The cBalance team ensures that all information available in relation to (solution name) has been shared with the household.

The cBalance team will reimburse any costs that might emerge due to damages caused by the prototype installation for a period of 12 months, since the date of installation. However, cBalance will not reimburse damages caused due to factors beyond control for eg. Natural calamities, fires, etc.

At the end of 12 months since the date of installation, if the residents express a desire to remove the solution cBalance team would get it removed.

Post 12 months since the date of installation, if residents express interest in retaining the solution, the cBalance team will not support any maintenance and would not be responsible for removal of the installed solution.

Signatories:

Home Owner Name:

Sign/Thumb Impression of Home Owner & Date:.....

Tenant name (if applicable)

:.....

Sign/Thumb Impression of Tenant & Date:.....

Project team member name

:.....

Sign/Thumb impression of cBalance team member & Date:

In collaboration with:

NGO partner name:

Name:.....
.....

Sign/Thumb impression &

Date:.....

8. Conduct Thermal Comfort Assessment Form Training

a. Rationale

- i. To train residents to document subjective thermal comfort data based on their lived experience before and after installation to assess the effectiveness of a given installation.

b. Engagement Approach

- i. Identify a place and time that is convenient to interact and facilitate the meeting with community members with the NGO partners support.
- ii. Invite community members to the meeting and check if the suggested day and time works for them.

Details training method and the assessment form template are mentioned in the box below.

A. Training Team Roles:

- A team member to explain the form filling process
- Team members to support residents to fill the demo form

B. Material:

- Form Booklets translated in the local language
- Pens

C. Training Approach:

- Explain the purpose of the form to residents
- Go through the form guidelines with residents
- Explain the purpose of each question in the form
- Give space to residents to clarify any doubts after each question

- Fill information under the 'General Information' section of the form booklet after explaining the booklets contents
- Ask residents to fill a demonstration form which will be the first form on the booklet, which will support with assessing their understanding of the form and also serve as a reference when they proceed to fill the forms at their houses
- At the end of the meeting inform residents that your team will be available in case they have any doubts while filling the forms later.

Assessment Form Content

a. Guidelines to fill the form-

- It is suggested that the score card be filled by all family members.
- Elders of the family can help kids to fill out forms.
- Keep the form preferably at the convenient position of the house.(So that you don't skip scoring).
- The form has to be filled 3 times a day for a period of 15-days.
- In the period of 15 days, the form has to be filled for 7 days before the installation and 7 days after the installation of the cooling solution.
- Add the exact time range below the time period.
- It is recommended to score all the indoor comfort levels by sitting /standing at the center of the house.
- It is recommended to score all the outdoor comfort levels by sitting /standing open space (Not under a tree or any shade). (you don't have to go very far from the house)
- There are 3 clothing types to choose from:
 - Light clothing = single layered clothing preferably cotton/ sleeveless/ half-length sleeves shirts, half-length pants, nightwear gown.
 - Medium clothing = Half-length/Full length sleeve Shirts, Full pants/trouser, sarees, dress,
 - Heavy clothing = Woollen sweaters, Jackets
- There are 3 activity levels to choose from:
 - Light Activity = Sitting, standing, reclining seat, sleeping.
 - Medium activity = Walking
 - Heavy activity = strenuous work like cleaning, washing, cooking, exercise, running.
- If you are not at home at any time you can skip the cell.
- Few questions have to be scored from 1 to 5, where-
 - 1 is for Unbearable
 - 2 is for Low comfort
 - 3 is for Bearable
 - 4 is for Comfortable
 - 5 is for Pleasant

b. General Information:



























































- Prototype Installed:

- House no.:
- Name of the representative household member:

c. Form Template

Day 1

Date:

Name of the family member 			
Time-Range	Breakfast 	Lunch 	Dinner 
Exact time of reading 			
Note: Kindly check the guidelines above for Light/Medium/Heavy			
What is the level of activity before filling the form? 	<input type="checkbox"/> Light  <input type="checkbox"/> Medium  <input type="checkbox"/> Heavy 	<input type="checkbox"/> Light  <input type="checkbox"/> Medium  <input type="checkbox"/> Heavy 	<input type="checkbox"/> Light  <input type="checkbox"/> Medium  <input type="checkbox"/> Heavy 
What cloth are you wearing while scoring? 	<input type="checkbox"/> Light  <input type="checkbox"/> Medium  <input type="checkbox"/> Heavy 	<input type="checkbox"/> Light  <input type="checkbox"/> Medium  <input type="checkbox"/> Heavy 	<input type="checkbox"/> Light  <input type="checkbox"/> Medium  <input type="checkbox"/> Heavy 
Is the fan switched on or off? 	<input type="checkbox"/> On <input checked="" type="checkbox"/> Off	<input type="checkbox"/> On <input checked="" type="checkbox"/> Off	<input type="checkbox"/> On <input checked="" type="checkbox"/> Off
Note: 1 is for Unbearable, 2 is for Low comfort, 3 is for Bearable, 4 is for Comfortable, 5 is for Pleasant			
Rate the thermal comfort - Inside 	<input type="checkbox"/> 1  <input type="checkbox"/> 2  <input type="checkbox"/> 3  <input type="checkbox"/> 4  <input type="checkbox"/> 5 	<input type="checkbox"/> 1  <input type="checkbox"/> 2  <input type="checkbox"/> 3  <input type="checkbox"/> 4  <input type="checkbox"/> 5 	<input type="checkbox"/> 1  <input type="checkbox"/> 2  <input type="checkbox"/> 3  <input type="checkbox"/> 4  <input type="checkbox"/> 5 
Rate the thermal comfort - Outside 	<input type="checkbox"/> 1  <input type="checkbox"/> 2  <input type="checkbox"/> 3  <input type="checkbox"/> 4  <input type="checkbox"/> 5 	<input type="checkbox"/> 1  <input type="checkbox"/> 2  <input type="checkbox"/> 3  <input type="checkbox"/> 4  <input type="checkbox"/> 5 	<input type="checkbox"/> 1  <input type="checkbox"/> 2  <input type="checkbox"/> 3  <input type="checkbox"/> 4  <input type="checkbox"/> 5 

9. Organise A Resident Experience Tour

a. Rationale

- To learn about the community's general acceptance of the installed solutions and their willingness to invest in them.
- To understand community member's inclination to have the prototypes that have been piloted in a few homes in their vicinity, installed in their homes
- To learn of any improvements that need to be made to the installation to suit the community's need and context, better.
- To gather insights on the communities alignment towards augmenting informal housing thermal comfort efforts with support from women-led small scale cooperative businesses in the future.

b. Engagement Approach

- i. Fix a date and time for the tour with support from NGO partner
- ii. Check if the date and time works for community members

Details of roles, responsibilities and tour design are mentioned in the below.

A. Roles and Responsibilities:

- Tour Guide - To lead community members to different houses during the tour and click photographs during the tour.
- Coordinator
 - To give an introduction to the tour
 - To coordinate between groups to ensure the smooth flow of the tour and also click photographs.
 - To also be available for any intermittent support needed during the tour /open house period (eg. to be at a given house when other team members need bio breaks, etc)
- Information sharing and data gathering person - To stay stationed at a given house and share information about a given prototype with tour participants and other visitors.
- Snack and drink distribution person - To be available at the snack and drink distribution counter and serve them to residents at the end of the tour.

B. Material:

- Tour route sheet
- Feedback form booklets
- Pens

C. Tips:

- Remember to take everything that comes in the spirit of learning eg. more/less people might come to the tour than expected and the tour might not go as planned, therefore approaching this event without any expectation might help deal with how things go on field gracefully.
- If you are unsure about your response to certain questions posed by residents you musn't be ashamed to admit it and can say that you will check with other team members and will inform the homeowner about the response later. In such cases make a note of the person's phone number so that you can get back to them.
- If someone is judging a solution in front of the homeowner and it seems like the homeowner is being negatively impacted by the comments, you can try and ask the person what they like about it to create a balance between positive and negative feedback.
- Keep the experimental nature of this process alive for the community eg. sharing failures with relevant prototypes.
- Emphasise to community members that the sole purpose of this exercise is to document their thoughts on these prototypes. This was an experiment through which your team hopes to learn about the effectiveness of these prototypes. Once we get feedback our intention is to

share these designs and skills with womens groups who can offer these solutions to more homes within the community themselves.

D. Tour format:

1. Tour participants and guides gather in one place at a pre-decided time and a short introduction is given about the tour.
2. Tour guides to follow the pre-planned route and lead participants to different houses.
3. Residents who are willing to complete the tour are led to all houses. Those who choose to discontinue the tour after an hour or in between are encouraged to continue but are not forced to stay.
4. One project team representative to be present in each house to share prototype details and collect feedback based on the feedback form when tour participants visit the house

E. Suggested scripts for interacting with residents:

1. Before beginning the tour/ for any resident who comes to the open house and is not part of the tour (parts from the script can be used as applicable) :

Welcome and thank you for coming!

We will be visiting some houses where we have worked on different thermal comfort solutions with the residents over the past year. These people came for some meetings where we had discussions about these solutions and they gave us their suggestions too. There have been some cases where we installed a prototype and there were some issues with them for eg. there was some leakage during the rains, and that was problematic to houses with solution.,etc. All the residents have stood by us as we worked on making these cooling solutions better.

Now we have worked on a total of..... (no.) different solutions with support from community members. We have installed these in..... (mention no. of houses) houses overall in(mention settlement name) We will share details about the thought behind these solutions and want your feedback on them to understand your thoughts on the installations. We will not be installing these in any more houses at the moment, because in the future we aim to work with women's groups who can offer effective and affordable solutions by operating a small-scale cooperative-business. This will help more communities deal with heat stress and also give women a source of livelihood, without being dependent on external entities for support. Therefore, we will be grateful if you can give us feedback so that we can learn about what works and what doesn't work and can take things forward, accordingly. We do not have any intention to commercialise these products.

Any questions?

2. At each house:
 - *Welcome!*
 - *This is called ----- (mention the name of the solution)*
 - *Let people observe the solution (2 mins per person)/ in cases where people cannot observe the solution keep videos/images handy*



Resident observing the Rooftop Garden solution during an Experience Tour in Pune

- *This is how this installation cools the place (Explain the working principle and mechanism using relatable examples)*
- *Do you have any questions?*
- *Fill the following feedback questionnaire at each house :*

Name :

Sex : Male/Female

Age :

1. How much would you rate this solution ?

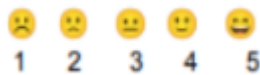

2. How much would you rate the solution's effectiveness in providing thermal comfort?

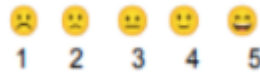

3. How much would you be willing to pay for this? What do you think would be a reasonable amount to pay for this?

4. Any feedback (things you like/dont like/concerns/questions)?.....
.....
.....

5. Can you think of anything that can make this solution better?.....
.....
.....

6. Any other thoughts/comments?
.....

3. After touring the final house :

- What are your thoughts after seeing the solutions?
- What are your thoughts on womens groups offering these solutions ?
- Would you like us to get in touch with you in case of any oppourtunities to work 'with' you in the future? If yes, please share your name/ phone no./house no.
- Thank you for your time.

10. Conduct Resident Critical Feedback Workshop

a. Rationale

- i. To create a space for residents who have thermal comfort solutions retrofitted in their houses to share their views and feedback on the issues and benefits of the installed prototype in their houses.
- ii. To receive inputs on a reasonable investment amount for the installation of a given solution in their homes.
- iii. To assess the communities alignment to having a women-led small scale cooperative business offering thermal comfort services in their locality.
- iv. To receive inputs on ways to enhance the approach of working with communities for future reference.

b. Engagement Approach

- i. Identify a place and time that is convenient to interact and facilitate the critical feedback workshop/meet them at their houses with the NGO partners support.
- ii. Invite community members to the workshop/inform them about the planned time of your visit to their home and check if the suggested day and time works for them.

Details of role, responsibilities and workshop/interview design are mentioned below.

A. Team Roles and Responsibilities:

- Facilitator: 1
- Design team members (to respond to community's questions): 1
- Documentation person (note taking and photography): 1
- Community mobilization person/s: 1

B. Material:

- Workshop flow document
- Images of installations
- Video capturing the projects journey in the locality (optional)

C. Workshop Flow (Approx. 1.5 hours)

1. Introduction (5 mins)

Suggested Script: Welcome! Thank you for working with us over the past year and for all the love and we have received from you. You'll have made us feel at home here and we are grateful to you for that. We are grateful that you stood by us even when things did not work out, in terms of issues that you faced during the rains, etc. You'll were also patient with us during the installation process, especially during times when we took more time to work on the installations than expected. There are some of you who were not there with us from the beginning and still trusted us and decided to work with us. Your trust in us is helping us move forward hopefully.

We have made a video that captures our journey together (show video)

We want to remind you as we had shared with you at the start that this is an experiment and as we go further on this journey, this will help us to learn about what works and what does not work which will help us when we work with women's groups in the future. The intention is to work with women's groups so that they can manufacture these solutions and provide them as products in their own communities. Therefore, your feedback is very valuable. We know that some of you gave us your feedback when we came to your homes, last time. However, it has been a while since then and we hope to learn about any more experiences you have to share with us today.

These are the ---- installations we will be discussing today. (show images))

Before commencing the critical feedback: Make an agreement that one person speaks at a time.

2. Critical feedback questions

Use the following format to discuss each installation :

- **General feeling: (5 mins)**
 - How are you feeling about the installation in your house?
 - Happy/Not happy

- **Issues: (30 mins)**
 - For those who are not happy - what are the issues you are facing with these installations?
 - Project team addresses concerns (if applicable)
 - *Any issues that are coming to your mind after listening to this?* (to others)
 - Project team addresses concerns (if applicable)
 - Issues you are anticipating in the future (during different seasons - summer, winter, monsoon)
 - Project team addresses concerns (if applicable)

- **Benefits: (20 mins)**
 - *We would like to know how this installation has benefitted you and your family members so far? (Prompt : Do you remember that initially, we had discussed a range of issues you'll face in summer such as difficulty in sleeping, doing housework, loss of appetite, children finding it difficult to study and the elderly finding it difficult to stay indoors)*

(prompt residents to share benefits during the day and night, both)

- **Recommendations: (10 mins)**
 - Any recommendations for things we can improve in the installations?
 - Any recommendations for things we can improve on based on how we have interacted with you?

- **Thoughts on investment: (10 mins)**
 - Would you recommend that others invest in this solution?

- What do you think would be a reasonable investment/ideal cost for these solutions?

- **Other thoughts: (5 mins)**

- Is there any other solution you might prefer now?
- Any other thoughts, comments, etc....? / questions from others. (10)

3. Wrapping up:

Suggested script : Thank you for sharing your thoughts and experiences with us. Our work here is not over, but it has just begun. We will be in touch with you to hear about how the installations are functioning. We are here in case you need any maintenance support, etc. Thank you for your time.

IV. Annexure

Cooling Solution Description Sheet For 'Participatory Design Workshop'

1. Water Filled PET Bottles

Sr. No	Topic	Details
1	Material Description	<ul style="list-style-type: none">• Water Filled PET Bottles OR• Water Filled PET Bottles in crates
2	Design Description	<ul style="list-style-type: none">• Water bottles are stuck with silicone glue over a tarpaulin sheet• Water bottles are placed in crates over the roof .
3	Working Principle	The water filled in PET bottles will absorb the sun's heat thereby reducing the amount of heat that reaches the roof directly and will help with keeping the indoor temperature cool
4	Relatable Examples	Thermal Mass: Have you heard of or seen people who tie a huge pagdi/turban on top of their heads? The twisted cloth acts like a thermal mass retarding the soaking up of heat.
5	Risks (eg. wind, rain)	Water accumulation
6	Maintenance needs	Bottle and water has to be replaced if it leaks or breaks.
7	Lifespan	2 years
8	Weight of the installation	<ul style="list-style-type: none">• PET bottles on the roof - 1 kg/ sqft• PET bottles with crates - 6.47 kg/sq.ft
9	Installation benefits	Thermal Comfort.
10	Installation limitations	<ul style="list-style-type: none">• PET bottles cannot be installed on concrete roofs as opposed to PET bottles with crates.• Reduction of accessible roof area

11	Estimated heat stress reduction (Average Under Roof Temperature)	PET bottles on roof : approx. 2-3 degree Celsius PET bottles in crates : approx. 0.2 - 4.8 degree Celsius

2. Rooftop Gardening

Sr. No	Topic	Details
1	Material Description	Green roof/plants cultivated on the rooftop.
2	Design Description	This installation consists of a layer of vegetation that can be cultivated in diverse ways above the roof eg. In pots, brick beds, wooden crates, grow bags, etc.
3	Working Principle	You may have experienced that you feel cool while standing under a tree. This is because the leaves provide shade and this is how the rooftop garden will function too. Additionally, the soil will absorb the heat, reducing the heat that penetrates through the roof, and will release this heat once the atmosphere cools down. This is another way in which this installation reduces indoor temperature.
4	Relatable Examples	<ul style="list-style-type: none"> ● Thermal Mass : Have you visited ancient historical buildings like forts, palaces etc? Is it cooler or hotter inside? The reason for it being cooler is because thick stones are used. ● Shading : Have you sat/stood under a tree when it's hot? If yes, how did that make you feel from a thermal comfort perspective?
5	Risks (eg. wind, rain)	Heavy winds/cyclones can uproot the plants.
6	Maintenance needs	Daily watering, periodic sowing, harvesting, guiding climbers, anti rust application to metal poles and composting.
7	Lifespan	7-8 years
8	Weight of the installation	3.3 kg/sqft
9	Installation benefits	<ul style="list-style-type: none"> ● Thermal comfort ● Produce from plants ● Aesthetic beauty ● Nature education for children/grown-ups who engage with the garden

10	Installation limitations	<ul style="list-style-type: none"> ● Cannot be installed in homes which lack roof access ● Reduction of accessible roof area.
11	Estimated heat stress reduction (Average Under Roof Temperature)	3-8 degree Celsius

3. Underroof Insulation Panels (Wood Wool Panel/Biomass Panels) Wrapped in Multi-Layered Plastic (MLP)

Sr. No	Topic	Details
1	Material Description	<ul style="list-style-type: none"> ● Biomass Panels are made from agricultural waste, plant fibres and waste paper. ● Wood Wool Panel is made from wood shreds/fibres, cement and water. ● Multi-Layered Plastic is the packaging material used in chips and biscuit packets having a layer of silver coating on the inside.
4	Design Description	Static solution to be installed under the roof.
3	Working Principle	Insulation: Wood Wool Panels/Biomass Panels wrapped in MLP create a barrier between outdoor heat and the persons under the roof, thereby reducing indoor temperature.
2	Relatable Examples	Insulation : Thermocol Ice box does not allow heat to come in and keeps ice intact
5	Risks (eg. wind, rain)	None
6	Maintenance needs	None
7	Lifespan	3 years
8	Weight of the installation	<ul style="list-style-type: none"> ● Wood Wool Panels - 0.4 kg/sqft ● Biomass Panels - 0.5 kg/sqft
9	Installation benefits	Thermal Comfort
10	Installation limitations	Solution cannot be installed over the roof
11	Estimated heat	<ul style="list-style-type: none"> ● Wood Wool Panels : approx 0.1 to 6.2 degree Celsius

stress reduction (Average Under Roof Temperature)	<ul style="list-style-type: none"> • Biomass Panels : approx 0.2 to 6.9 degree Celsius
---	---

4. Internal Dynamic Barrier

Sr. No	Topic	Details
1	Material Description	Multi-Layered Plastic (MLP) is the packaging material used in chips and biscuit packets having a layer of silver coating on the inside.
4	Design Description	The installation consists of a series of low emissivity surfaces curtailing radiant heat emitted by the metal/ asbestos roofs.
3	Working Principle	Radiant barrier (day) : The Internal Dynamic Barrier is like a manual curtain mechanism where the curtain can be folded and unfolded as required. The solution works on the principle of Radiant Barrier + Night Sky Radiation. It works as a Radiant Barrier during the day and facilitates Night Sky Radiation at night. This is a dynamic solution as it allows for open and close movement during different times of the day. The solution needs to be closed during the day (around 8-9 AM covering the roof) and open during the evening/night (post 5-6 PM) and rain.
2	Relatable Examples	Like sunshades diminish the direct glare, the deployed radiant barrier cuts down a subtle continuous radiant heat emitted by the roof to the inhabitants. As the shades are removed once we enter an area without direct glare, the barrier too is retracted when the incoming radiant heat has terminated(post sunset).
5	Risks (eg. wind, rain)	Relatively safe with no risks as it is placed in the interior. Direct flame or heat is a potential risk arising from cooking, prayer niche, etc.
6	Maintenance needs	As the barrier is a horizontal surface, a lot of dust can settle on top. While operating this can fall onto inhabitants. Hence this might need regular dusting of the rear side of the barrier as well as the reflective surface of the barrier with a soft cloth. Greasing for
7	Lifespan	3 years
8	Weight of the installation	0.1 kg/ sq.ft

9	Installation benefits	Reduction in perceived heat
10	Installation limitations	Lack of dynamism around ceiling fan
11	Estimated heat stress reduction	<ul style="list-style-type: none"> ● Roof Radiant Temperature: 0 degree Celsius - 23.9 degree Celsius ● Solution + Vertical Cane Blind (described below) : Mean Radiant Temperature: 0 degree Celsius-7.4 degree Celsius

5. Vertical Bamboo Blinds with Multi-Layered Plastic

Sr. No	Topic	Details
1	Material Description	Multi-Layered Plastic (MLP) is the packaging material used in chips and biscuit packets having a layer of silver coating on the inside.
2	Design Description	Bamboo blinds are typically crafted from bamboo, a fast-growing and renewable resource. The bamboo is woven into slats that are then attached to a blind mechanism. Cane blinds with MLP/ Alufoil on the inside acts as a radiant barrier.
3	Working Principle	<p>Radiant barrier (day)</p> <p>MLP is a material which functions like a cap that shields those who wear it from the sun's rays. During the day when it is covered it functions like a cap that shields the roof from the sun, and at night when it is opened it makes way for heat that is trapped inside the house to escape and cools the temperature indoors, just like you would feel some relief after removing your cap when you are in the shade.</p> <p>Shading. :</p>
4	Relatable Examples	<ul style="list-style-type: none"> ● Radiant Barrier : Cap/Umbrella used during the day to avoid heat
5	Risks (eg. wind, rain)	<ul style="list-style-type: none"> ● Heavy winds & rains can damage the panels ● Anchor fasteners/bolts need to be drilled carefully else they can cause leakage issues
6	Maintenance needs	<ul style="list-style-type: none"> ● Cleaning the reflective surface from the accumulation of dust. ● Ensuring water isn't trapped in for long periods post rain - inducing faster decomposition of the Bamboo Blind.
7	Lifespan	3 years
8	Weight of the installation	0.3 kg/sqft
9	Installation	Thermal Comfort

	benefits	
10	Installation limitations	None
11	Estimated heat stress reduction	Solution + Vertical Cane Blind (described below) : Mean Radiant Temperature: 0 degree Celsius-7.4 degree Celsius

6. Space Frame with Multi-Layered Plastic (MLP)

Sr. No	Topic	Details
1	Material Description	Multi-Layered Plastic (MLP) is the packaging material used in chips and biscuit packets having a layer of silver coating on the inside.
2	Design Description	The Radiant Barrier Space Frame is like a manual curtain mechanism where the MLP sheet can be folded and unfolded as required to enable radiant barrier and night sky radiation principles. The MLP attached to the tarpaulin sheet is supported on the rope which winds and unwinds enabling opening and closing of the barrier. Pulleys to operate the opening and closing of the mechanism. Since this solution is modular, each module has its own separate pulleys for handling mechanism.
3	Working Principle	Radiant barrier (day), radiation through night sky (night): MLP is a material which functions like a cap that shields those who wear it from the sun's rays. During the day when it is covered it functions like a cap that shields the roof from the sun, and at night when it is opened it makes way for heat that is trapped inside the house to escape and cools the temperature indoors, just like you would feel some relief after removing your cap when you are in the shade.
4	Relatable Examples	<ul style="list-style-type: none"> ● Radiant Barrier : Cap/Umbrella used during the day to avoid heat ● Night Sky Radiation : Using a cap for a long time results in the head getting hot. If we move to a cooler surrounding(Ex: cool room with fan, cooler) and if cap is not removed the head is still hot due to excessive sweat/heat getting trapped.If we remove the cap head will cool down faster
5	Risks (eg. wind, rain)	<ul style="list-style-type: none"> ● Heavy winds & rains can damage the panels ● Can't be deployed in areas where external entities like falling coconuts or monkey menace is predicted.
6	Maintenance needs	Periodic lubrication required for runners- once every quarter.
7	Lifespan	3 years
8	Weight of the installation	0.89 kg/sqft

9	Installation benefits	Thermal Comfort
10	Installation limitations	Reduction of accessible roof area
11	Estimated heat stress reduction	Roof Radiant Temperature: 0 degree Celsius - 23.9 degree Celsius

Informal Housing Thermal Comfort

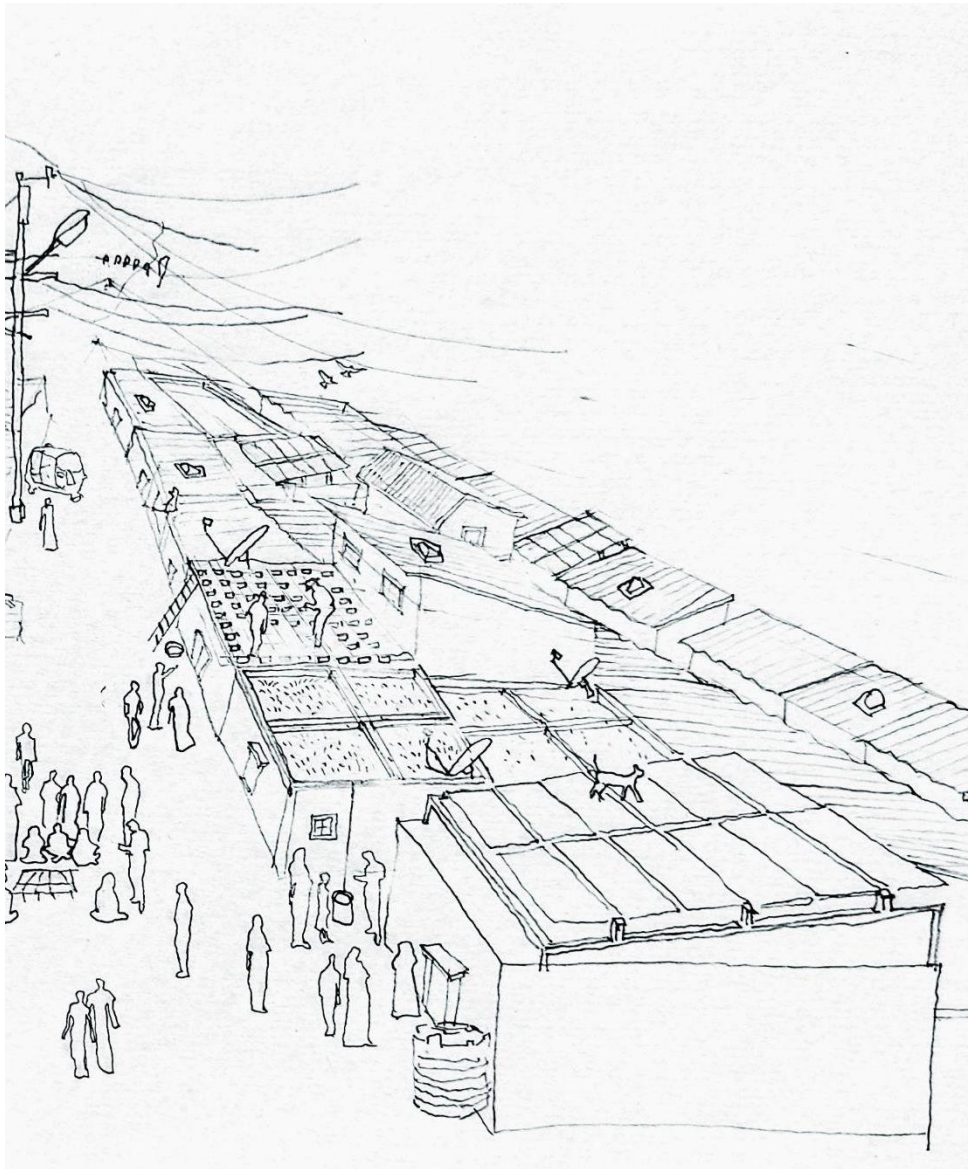

Technical Brief

August 2025

Table of Contents :

1. General Technical Brief	6
1.1. Fabrication.....	6
1.1.1. Metal Fabrication	6
1.1.1.1. Cutting	6
1.1.1.2. Bending	7
1.1.1.3. Drilling	8
1.1.1.4. Welding.....	9
1.1.2. PVC Pipe Fabrication	10
1.1.2.1. Cutting	10
1.1.2.2. Drilling	10
1.1.2.3. Screwing.....	11
1.1.3. Tarpaulin Fabrication	11
1.1.3.1. Cutting	11
1.1.3.2. Folding.....	12
1.1.3.3. Stitching.....	12
1.1.4. Bamboo Fabrication.....	12
1.1.4.1. Cutting	12
1.1.4.2. Splitting Process	13
1.1.4.3. Shaping	13
1.1.4.4. Joining	14
1.1.4.5. Finishing	14
1.2. Installation	14
1.2.1. Plumbing Work	14
1.2.1.1. Site Preparation	14
1.2.1.2. Piping and Alignment	14
1.2.1.3. Valve and Fixture Installation	15
1.2.1.4. Insulation and Protection	15
1.2.1.5. System Testing and Commissioning	15
1.2.2. Bamboo Placing	15
1.2.3. Curtain Installation	15
1.2.4. Pulley Arrangement	15
1.2.5. Wire Rope Tightening	15
1.2.6. Placing The Pots	15
1.3. Post-Installation Check.....	15

2.	Cooling Solution-Specific Technical Brief.....	16
2.1.	Internal Dynamic Barrier.....	16
2.1.1.	Pre-Installation Staging.....	16
2.1.2.	Fabrication.....	16
2.1.3.	Installation.....	24
2.1.4.	Operation.....	27
2.1.5.	Maintenance.....	27
2.1.5.1.	Monthly Maintenance Checklist.....	27
2.1.5.2.	Quarterly Maintenance Checklist.....	27
2.1.5.3.	Annual Maintenance Checklist.....	27
2.1.6.	Do's and Dont's.....	27
2.2.	Biomass Panels.....	27
2.2.1.	Pre-Installation Staging.....	27
2.2.2.	Biomass Panel Fabrication.....	28
2.2.3.	Wrapping the Panel with MLP.....	38
2.2.4.	Installation.....	39
2.2.5.	Maintenance.....	43
2.2.5.1.	Monthly Maintenance.....	43
2.2.5.2.	Quarterly Maintenance.....	43
2.2.5.3.	Annual Maintenance.....	43
2.2.6.	Do's and Dont's.....	44
2.3.	Wood Wool Panels.....	44
2.3.1.	Pre-Installation Staging.....	44
2.3.2.	Installation.....	44
2.3.3.	Maintenance.....	48
2.3.3.1.	Monthly Maintenance.....	48
2.3.3.2.	Quarterly Maintenance.....	48
2.3.3.3.	Annual Maintenance.....	48
2.3.4.	Do's and Dont's.....	49
2.4.	Rooftop Garden.....	49
2.4.1.	Pre-Installation Staging.....	49
2.4.2.	Fabrication.....	51
2.4.3.	Installation.....	52
2.4.4.	Maintenance.....	64
2.4.4.1.	Monthly Maintenance.....	64
2.4.4.2.	Quarterly Maintenance.....	65

2.4.4.3.	Annual Maintenance	65
2.4.5.	Do's and Dont's	65
2.5.	Water Filled PET Bottles.....	66
2.5.1.	Pre-Installation Staging.....	66
2.5.2.	Fabrication.....	66
2.5.3.	Installation	68
2.5.4.	Maintenance.....	72
2.5.4.1.	Monthly Maintenance.....	72
2.5.4.2.	Quarterly Maintenance.....	72
2.5.4.3.	Annual Maintenance	72
2.5.5.	Do's and Dont's	73
2.6.	Water Filled PET Bottles In Crates	73
2.6.1.	Pre-Installation Staging.....	73
2.6.2.	Fabrication.....	73
2.6.3.	Installation	74
2.6.4.	Maintenance.....	78
2.6.4.1.	Monthly Maintenance.....	78
2.6.4.2.	Quarterly Maintenance.....	78
2.6.4.3.	Annual Maintenance	78
2.6.5.	Do's and Dont's	78
2.7.	Space Frame.....	79
2.7.1.	Pre-Installation Staging.....	79
2.7.2.	Fabrication.....	79
2.7.3.	Installation	89
2.7.4.	Operation.....	90
2.7.5.	Maintenance.....	90
2.7.5.1.	Monthly Maintenance.....	90
2.7.5.2.	Quarterly Maintenance.....	90
2.7.5.3.	Annual Maintenance	91
2.7.6.	Do's and Dont's	91
2.8.	Vertical Bamboo Blind	91
2.8.1.	Pre-Installation Staging.....	91
2.8.2.	Fabrication.....	92
2.8.3.	Installation	94
2.8.4.	Operation.....	95
2.8.5.	Maintenance.....	95



2.8.5.1.	Monthly Maintenance	95
2.8.5.2.	Quarterly Maintenance.....	95
2.8.5.3.	Annual Maintenance	96
2.8.6.	Do's and Dont's	96

1. General Technical Brief

1.1. Fabrication

1.1.1. Metal Fabrication

1.1.1.1. Cutting

- Verify material specifications (type, size, thickness)
 - If material specification is not done properly, then incorrect material may be used, leading to defective parts or scrap.
- Check for any surface defects or damage
 - If defects are not identified, then they may affect the cutting process or final product quality.
- Confirm cutting plan and sequence
 - If cutting plan and sequencing is not followed then errors in cutting sequence or dimensions may occur.
- Ensure proper safety gear is worn
 - If proper safety gear (safety gloves, safety helmet, safety goggles etc) is not worn, then the operator may be at risk of injury from sharp edges or debris.
- Check for correct cutting tool and equipment for material type
 - If incorrect tools are used, then cuts may be of poor quality or tool/equipment may be damaged.
- Cutting Process Checks:
 - Monitor cutting process for accuracy and quality
 - If the process is not monitored, then errors or defects may go unnoticed.
 - Use templates or jigs for cutting the complex shapes for precision
 - If templates or jigs are not used, then cuts may not be accurate which leads to defective parts.
- Post-Cutting Checks:
 - Inspect cut edges for quality and accuracy
 - If thorough inspection is not done, then defects or errors may go unnoticed.
 - Deburr the cut edges
 - If cut edges are not deburred then it affects the final product quality.
 - Verify dimensions and tolerances
 - If dimensions are not verified then parts may not be fit for function correctly.
 - Adjust equipment or process if cuts are not meeting specifications

- If adjustments are not made then continued production may result in more defective parts.

1.1.1.2. Bending

- Pre-Bending Checks:
 - Check the internal radius of the bend
 - a minimum radius (often at least 1x thickness, or R/T ratio) is needed to prevent cracking.
 - Check Bend Angle
 - Check the final desired angle of the bend to avoid defective parts, rework, assembly or functional issues.
 - Check the Bend Line
 - Check the specific line along which the bend will occur to prevent error in bending along specific lines to prevent defective parts, rework, assembly or functional issues.
 - Bend Allowance/K-factor
 - Check the length of the material along the neutral axis of the bend that is required for a specific angle and bend line. Incorrect bend allowance calculation may result in insufficient or material “stretch” during bending.
 - Check bending Force
 - Check the pressure required to make the bend, which is affected by the material, thickness and the length.
 - Insufficient bending force may result in incomplete or partial bend, incomplete bend angle, increased springback(returning to its original shape)
 - Excessive bending force may result in over-bending or deformation of the material, cracking or fracture, damage to the bending tool or equipment..
 - Check bend Sequence
 - Check the order in which bends are performed, which can affect the final part.
 - Specify process Tolerances
 - Specify acceptable tolerances for dimensions and angles. Any error in acceptable tolerance will lead to dimensional inaccuracies, quality issues, rework or increased scrap, assembly or functional problems.
 - Ensure proper safety gear is worn
 - If proper safety gear (safety gloves, safety helmet, safety goggles etc) is not worn, then the operator may be at risk of injury from insufficient or excessive bending force.
- Bending Process Checks:
 - Use correct bending tools and equipment for material type
 - If incorrect tools are not set correctly, then bends may be of poor quality or material may be damaged.

- Set correct bending parameters(angle, radius etc)
 - If incorrect bending parameters are used, then bends may not meet specifications and result in defective parts.
- Monitor bending process for accuracy and quality
 - If the bending process is not monitored, errors or defects may go unnoticed.
- Post-Bending Checks:
 - Inspect bent parts for quality and accuracy
 - If thorough inspection is not done, then defects or errors may go unnoticed.
 - Verify dimensions and angles meet specifications
 - If dimensions are not verified then parts may not be fit for function correctly.
 - Check for any sign of material stress or deformation
 - If stress or deformation is not identified, then parts may fail in service.
 - Adjust equipment or process if cuts are not meeting specifications
 - If adjustments are not made then continued production may result in more defective parts.

1.1.1.3. Drilling

- Pre-Drilling Checks:
 - Confirm drilling plan and sequence
 - If the drilling plan is not verified, then errors in hole location or size may occur.
 - Check for any surface defects or damage
 - If defects are not identified then they may affect the drilling process or hole quality.
 - Ensure proper safety gear is worn
 - If proper safety gear (safety gloves, safety helmet, safety goggles etc) is not worn, then the operator may be at risk of injury from sharp edges or debris.
- Drilling Process Checks:
 - Use correct drill bits and equipment for material type
 - If incorrect drill bits are used, then holes may be of poor quality or drill bits may be damaged.
 - Set correct drilling parameters(speed, feed rate etc)
 - If incorrect drill bits are used, then holes may be of poor quality or drill bits may be damaged.
 - Monitor drilling process for accuracy and quality
 - If drilling process is not monitored, errors or defects may go unnoticed
 - Use lubricant as necessary
 - If lubricant is not used, then drill bits may overheat or wear excessively.

- Post Drilling Checks:
 - Verify hole size and location with specifications
 - If holes do not meet specification, then parts may not fit or function correctly.
 - Deburr the holes
 - If holes are not deburred then it affects the final product quality.
 - Adjust equipment or process if holes are not meeting specifications
 - If adjustments are not made then continued production may result in more defective parts.

1.1.1.4. Welding

- Pre-Welding Checks:
 - Verify material specifications (type, size, thickness)
 - If material specification is not done properly, then incorrect welding parameters may be used, leading to defective parts or scrap.
 - Confirm welding plan and sequence
 - If the welding plan is not verified, then errors in weld location or quality may occur.
 - Ensure proper fit-up and alignment of the parts
 - If parts are not properly aligned, then weld may be uneven or defective.
 - Clean and prepare the surface to be welded
 - If surfaces are not clean, then weld quality may be compromised, leading to defects.
 - Ensure proper safety gear is worn
 - If proper safety gear (safety gloves, safety helmet, safety goggles etc) is not worn, then the operator may be at risk of injury from sharp edges or debris.
- Welding Process Checks:
 - Use correct welding process and equipment for material type
 - If an incorrect welding process is used, then weld may be of poor quality or material may be damaged.
 - Set correct welding parameters(voltage, current, speed etc)
 - If incorrect parameters are set, then welds may not meet the specifications or material may be damaged.
 - Monitor welding process for accuracy and quality
 - If the welding process is not monitored, errors or defects may go unnoticed.
 - Use proper shielding gas and consumables
 - If the proper shielding gas or consumables are not used correctly, then weld quality may be compromised.
- Post Welding Checks:
 - Inspect weld for quality and accuracy
 - If inspection is done thoroughly, then defects or errors may go unnoticed.

- Verify weld strength and integrity meet the specification
 - If welds do not meet specification, then parts may not be structurally sound.
- Check for distortion or warping
 - If distortion or warping is not identified, then parts may not fit or function properly.
- Adjust equipment or process if holes are not meeting specifications
 - If adjustments are not made then continued production may result in more defective parts.

1.1.2. PVC Pipe Fabrication

1.1.2.1. Cutting

- If the diameter is less than 2 inches
 - Use a ratcheting PVC cutter for clean, burr-free cuts.
- If the diameter is more than 2 inches
 - Then opt for a fine toothed hacksaw or miter saw to minimize splintering.
- If using a power saw
 - Then ensure the blade speed is low (under 3000 RPM) to prevent melting the PVC material.
- If cut edge shows burr or roughness
 - Then deburr with a utility knife or sandpaper to ensure smooth fitting assembly.
- If cutting multiple pipes to the same length
 - Then use a measuring tape and stop block for consistency.
- If precision is critical
 - Then employ a digital caliper for verification.

1.1.2.2. Drilling

- If drilling holes smaller than ½ inch
 - Then use a standard twist drill bit.
- If drilling holes larger than ½ inch
 - Then use a spade or hole saw bit designed for plastics to avoid cracking.
- If the PVC is thin-walled(Schedule 40 or less)
 - Then drill at low speed (500-1000RPM) with light pressure to prevent melting or fracture
- If the PVC is thicker (Schedule 80)
 - Then moderate speed is acceptable.
- If the hole need to be precise in location
 - Then mark with a centre punch and use a drill guide.
- If multiple holes are required
 - Then create a template for alignment.

- If debris accumulates during drilling
 - Then pause to clear chips to avoid overheating.
- If the material softens
 - Then apply a coolant like water or stop to let it cool.
- If drilling near the pipe end
 - Then support the interior with a wooden dowel to prevent collapse
- If the pipe is curved
 - Then use a flexible drill extension for access.

1.1.2.3. Screwing

- If using threaded fittings
 - Then apply PVC primer and cement first for non-threaded joints.
- If threads are involved
 - Then use a PTFE tape on male threads to ensure a leak-proof seal.
- If screwing with self-tapping screws
 - Then pre-drill pilot holes 80% of the screw diameter to avoid splitting
- If the PVC is brittle
 - Then use screws with coarse threads for better grip.
- If torque is applied manually
 - Then hand-tighten plus ¼ turn.
- If using a power driver
 - Then set to low torque (under 20 in-lbs) to prevent stripping or cracking.
- If assembling in wet conditions
 - Then use waterproof thread sealant
- If assembling in high pressure applications
 - Then verify fittings are rated for the PSI to avoid failure.
- If disassembling is anticipated
 - Then prefer mechanical screws over glued joints
- If permanent assembly is required
 - Then combine screwing with adhesive for reinforced strength.

1.1.3. Tarpaulin Fabrication

1.1.3.1. Cutting

- If tarpaulin roll is large or requires consistent dimensions across multiple pieces
 - Then use an automated or computer controlled cutting machine on a flat table
- If cutting smaller custom pieces manually

- Then mark the measurements with chalk and use sharp-heavy scissors to prevent fraying or uneven edges
 - If material has a coated side (PVC or polyethylene)
 - Then cut with the coated side facing up to minimize scratches or damage during handling.

1.1.3.2. Folding

- If preparing hems for reinforcement
 - Then fold the edges inward by 1-2 inches (single or double fold based on thickness), use weights to hold folds in place for accuracy.
- If folding for multi-panel assembly
 - Then align edges precisely and fold along marked lines
- If misalignment occurs
 - Then unfold and reposition to prevent wrinkles
- If incorporating eyelets later
 - Then ensure folds are wide enough (at least 2 inches) to accommodate reinforcement
- If folding in a high-volume production
 - Then use folding jigs or template for consistency
- If folding manually
 - Then measure each fold with a ruler to maintain uniformity.

1.1.3.3. Stitching

- If using sewing machines for hems
 - Then select heavy-duty needles(e.g., size 16-18)
- If joining multiple panels
 - Then use a flat-felled or overlap seam with double stitching for waterproofing
- If seams leak during testing
 - Then apply seam sealant post-stitching.
- If quality control detects uneven stitching
 - Then inspect and restitch affected areas, always backstitch at ends to secure threads against unraveling.

1.1.4. Bamboo Fabrication

1.1.4.1. Cutting

- Pre-Cutting Checks:
 - If the bamboo is freshly harvested and shows signs of high moisture (e.g., green color or flexibility)
 - Then allow it to dry naturally in a shaded, ventilated area for 4-6 weeks to prevent cracking during processing.

- If the intended use is for load-bearing structure
 - Then select mature bamboo poles(3-5 years old) with uniform diameter and straight growth
- If the intended use is for light weight application
 - Then select younger poles
- If pests or fungi are visible on the surface
 - Then treat with natural preservatives like borax solution before proceeding to cutting.
- Cutting Process:
 - If the bamboo pole length exceeds the required size by more than 20%
 - Then mark cutting points at nodes to maintain strength and avoid splitting, cut using a sharp saw or machete perpendicular to the grain.
 - If cutting tools are dull
 - Then sharpen them first to ensure clean cuts, otherwise ragged edges may lead to uneven splitting later.
 - If cut sections are intended for immediate use
 - Then remove any branches or leaves at the nodes.
 - If cut sections are intended for later use and storing
 - Then bundle and store vertically to prevent warping.

1.1.4.2. Splitting Process

- If the bamboo diameter is greater than 10cm
 - Then use a splitting knife or wedge starting from the thinner end to create even strips
- If the bamboo diameter is less than 10cm
 - Then split manually with a mallet for finer control.
- If splits show irregular tearing or fiber damage
 - Then apply light oil to the tool blade for smoother penetration, otherwise proceed directly if bamboo is well-dried.
- If the desired strip width is less than 2cm for weaving
 - Then splits into quarters first and refine further
- If desired strip is for construction purpose
 - Then aim for wider halves or thirds to retain structural integrity.

1.1.4.3. Shaping

- If shaping requires bending (e.g., for curves)
 - Then heat the strip over a flame or steam them for 10-15 minutes until pliable.
- If shaping does not require bending
 - Then proceed to planing or sanding for flat surfaces.
- If the surface is rough or uneven after splitting
 - Then use a plane or scraper to smooth.
- if knots are present

- Then sand them down carefully to avoid weakening the material.

1.1.4.4. Joining

- If joining for permanent structures
 - Then use natural bindings like rattan or screws with pilot holes to avoid cracking.
- If joining for temporary structures
 - Then opt for lashing with ropes or wires.
- If joints involve end-to-end connections
 - Then use fish-mouth cuts or dowels for alignment.
- If joints involve side-to-side connections
 - Then apply adhesive like epoxy after sanding contact surfaces for better adhesion.
- If the assembly shows gaps or instability after initial
 - Then reinforce additional braces or glue, otherwise test load-bearing capacity before final use.

1.1.4.5. Finishing

- If final product will be exposed to the weather
 - Then apply a protective coating like varnish or oil.
- If final product will be used indoors
 - Then apply polish for aesthetics.
- If any cracks appear during or after processing
 - Then discard affected pieces and restart with new material.

1.2. Installation

1.2.1. Plumbing Work

1.2.1.1. Site Preparation

- Verify material specifications (type, size, thickness)
 - If material specification is not done properly, then incorrect material may be used, leading to defective parts or scrap.
- Check for any defects or damage pieces
 - If defects are identified, then they may affect the cutting process or final product quality.
- Check for correct cutting tool and equipment for material type
 - If incorrect tools are used, then cuts may be of poor quality or tool/equipment may be damaged.
- Confirm plumbing plan and sequence
 - If cutting plan and sequencing is not followed then errors in cutting sequence or dimensions may occur.

1.2.1.2. Piping and Alignment

- Install supports at 1m intervals for exposed pipes. If supports are plumb and gaps comply

- Then connect to fixtures, else realign and reinforce supports.

1.2.1.3. Valve and Fixture Installation

- Install valves (e.g., stop cocks, gate valves etc) at inlets and tees. Ensure flow direction and accessibility.
 - If valves are operable and oriented correctly, then proceed to testing; else replace or reorient and verify.

1.2.1.4. Insulation and Protection

- Insulate hot water pipes. Wrap underground copper pipes with protective tape.
 - If insulation is intact and if there are no corrosion risks, then integrate with the system; else apply additional protection and reinspect.

1.2.1.5. System Testing and Commissioning

- Conduct water/air tests on the full system. Install backwater valves where required and label cleanouts.
 - If tests hold pressure and no leaks are detected, then approve for use and clean site; else locate issues, repair and retest.

1.2.2. Bamboo Placing

This section is covered under the Roof Top Garden solution subhead.

1.2.3. Curtain Installation

This section is covered under the Space Frame and Internal Dynamic Barriers solutions subhead.

1.2.4. Pulley Arrangement

This section is covered under the Space Frame and Internal Dynamic Barriers solutions subhead.

1.2.5. Wire Rope Tightening

This section is covered under the Space Frame and Internal Dynamic Barriers solutions subhead.

1.2.6. Placing The Pots

This section is covered under the Roof Top Garden solution subhead.

1.3. Post-Installation Check

- 1.3.1. Ensure that the fabricator has completed the work as per design specifications.

- 1.3.2. For static solutions, conduct a knock test for panels by knocking 5 times each at all the corners, 3 random places along the edges, and 5 random places in between.
- 1.3.3. For dynamic solutions, open and close the solution fifty times.
- 1.3.4. Look closely for any cracks, gaps, alignment issues and damages to the structure and rectify them if found.

2. Cooling Solution-Specific Technical Brief

2.1. Internal Dynamic Barrier

2.1.1. Pre-Installation Staging

A. Supports:

- Determine the orientation of the fractal, i.e. the direction of movement for the fractal.
- Identify a location that the steel wires can be supported from, either by anchoring to the wall or welding to metal purlins on the roof.

B. Placement and Design Decisions :

- Implement a static barrier, for roof regions around the fan.
- Implement a dynamic barrier, for the rest of the roof.

C. Removal and Rerouting of Barriers to Dynamic Movement :

- Rewire and reposition lights and other electrical fixtures that might hinder the movement of the dynamic barrier.

2.1.2. Fabrication

A. Establish Supports:



Figure 1.1 : Support taken from a metal section

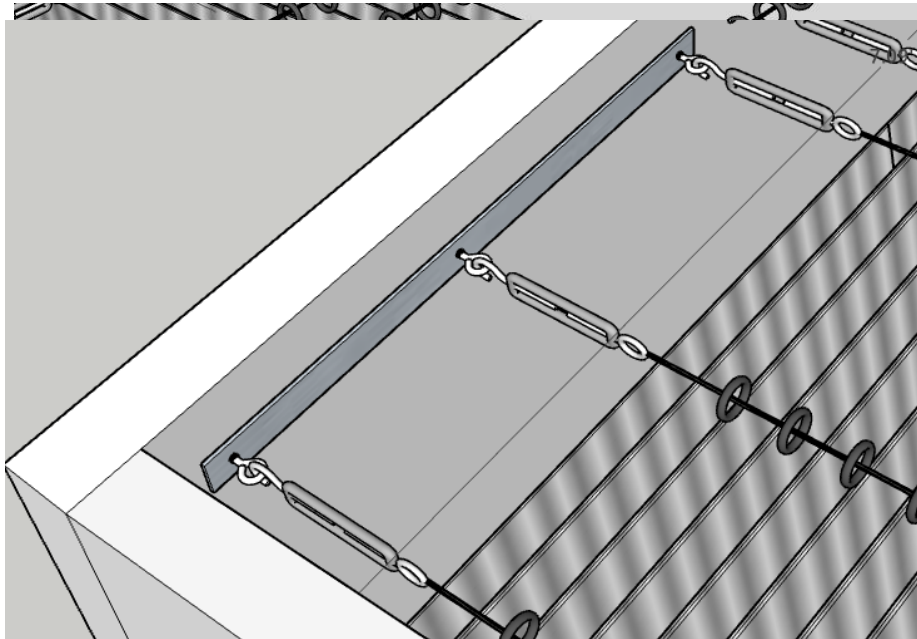

Figure 1.2: Bracing in case of unplastered wall



Figure 1.3: Establishing wire rope to wall using U-clamps

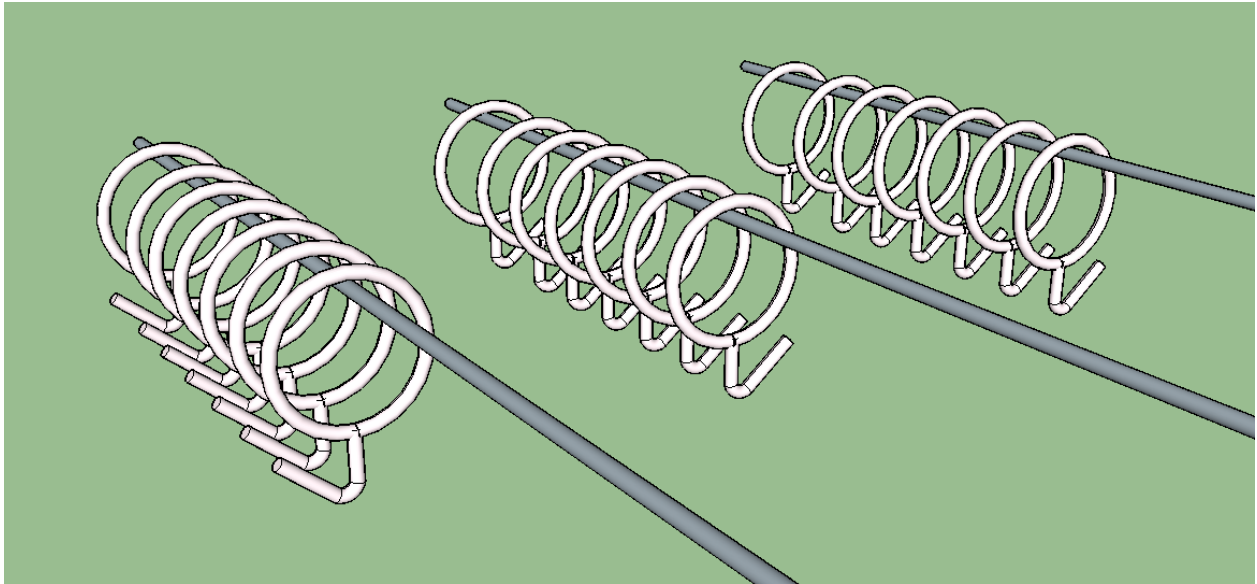

Figure 1.4: Orientation of curtain rings



Figure 1.5: Establishing wire rope to wall using U-clamps

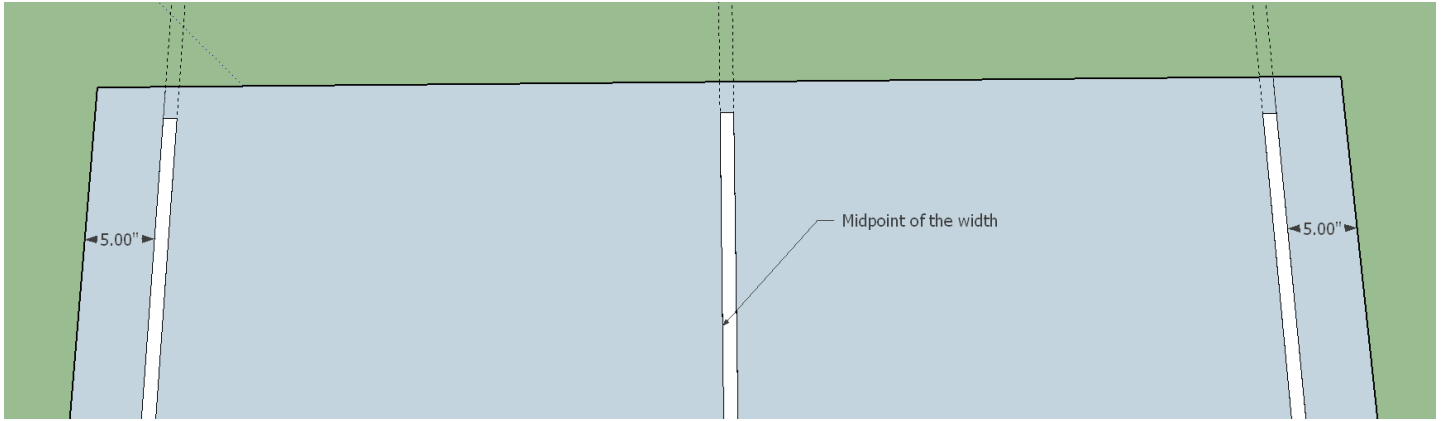

Figure 1.6: Placement of curtain runner



Figure 1.7: Curtain runners stitched into Astar Fabric



Figure 1.8: Attaching MLP and Astar fabric together with ziplock using Ductape

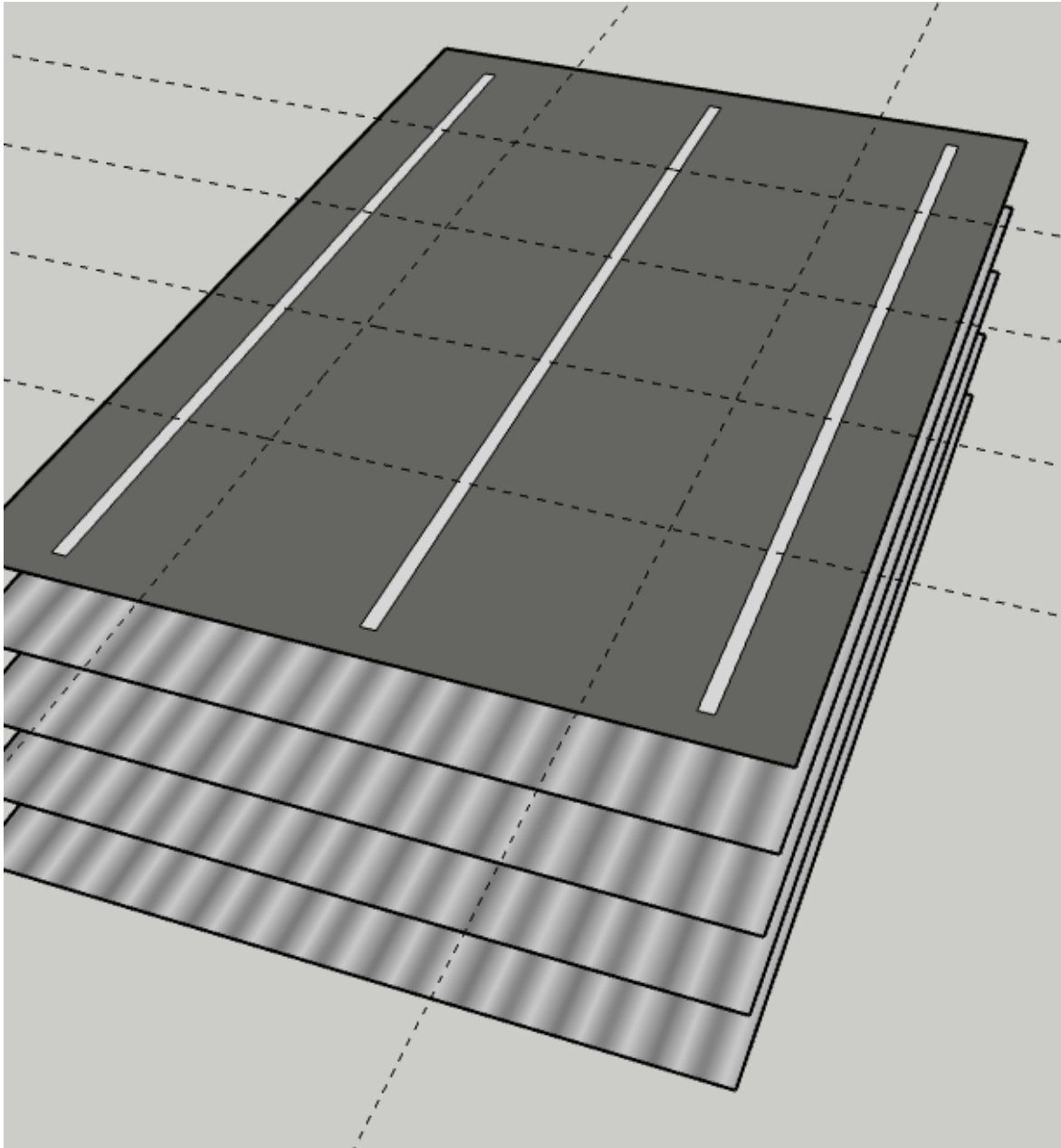

Figure 1.9: Arrangement of Astar with curtain runner and MLP sheets with placement of ties



Figure 1.10: Folding and Stapling along the edges

2.1.3. Installation



Figure 1.11: Hooking of eyelets to the curtain runner on Dynamic Barrier



Figure 1.13: Attaching nylon rope to the front end pipe of the fractal



Figure 1.14: Handling mechanism at rear end - nylon wire loop going through two individual hooks.



Figure 1.15: Handling mechanism at front end - nylon wire loop going through front hook.

2.1.4. Operation

- Pulling one side of the nylon wire loop down would unfurl the fractal and the other end would retract it back.
- Tug at the nylon wire with uniform gentle force and not spurts of violent force.
- In case any resistance is observed, kindly pull back in the opposite direction and retry.

2.1.5. Maintenance

2.1.5.1. Monthly Maintenance Checklist

- Use a dry and soft cloth to clean the shiny surface of the installation.

2.1.5.2. Quarterly Maintenance Checklist

- Grease the PVC coated steel wires, over which the Dynamic Barrier slides, every quarter.
- Introduce tension into the system by tweaking at the tension fastener, as and when any sag is observed in the fractal.

2.1.5.3. Annual Maintenance Checklist

- Clean the rear end of the fractal i.e. the side facing the roof, by uninstalling the fractal by untangling hooks from the curtain runner.

2.1.6. Do's and Dont's

- Ensure that the dynamic barrier is used as such - like a dynamic barrier: extended (i.e. covering the roof bottom surface) in the day-time at about 7 am, and retracted (folded to expose the roof bottom surface) in the night-time at about 6pm.
- Do not use the steel wire ropes to hang or suspend any heavy object(s).

2.2. Biomass Panels

2.2.1. Pre-Installation Staging

Over the roof

- Ensure that the roof is leak proof :
 1. Clean the roof thoroughly to identify repair points.
 2. Identify weak points such as J hooks.
 3. Fill in the weak points and cracks with cement mortar and waterproof solution.
 4. Ensure that the application of any sealant on a corrugated roof does not hamper smooth water flow during rains.
- In cases where there are lots of cracks and multiple joints in the roof owing to multiple roofing sheets placed of small sizes, considering the context is houses in informal settlements made up of quick fix materials, cover the roof with Silpaulin sheet to prevent the leakage inside the house over the installed panels.

Under the roof

- Remove all the items in the house that are inflammable such as clothes lying in the open, bedsheets or cover bedspreads with wet sheets, cylinder, etc. to avoid risk of catching fire from sparks of Metal welding and glander cutter.
- Study the roof slope and mark the level of the installation on the four walls, either parallel to the slope or straight. Ensure a minimum gap between roof and panel installation layer of 6” for air insulation and electrical wiring/repair.
- Ensure that the clear height from the floor post the installation and other contextual objects present such as electrical wiring, fan, etc. is minimum 6’6” to have a psychological comfort and safety.
- Once the installation level is planned, remove the fans or reposition lights and any other electrical fixtures that hinder the installation of the panels, below the level of installation to make the roof ready for the installation.

2.2.2. Biomass Panel Fabrication

The panels are being made by the GramArt¹ Project in Paradsingha, a village in the Maharashtra-Madhya Pradesh border. They are completely handmade. Below are the steps of the process of the panel making.

- Identify plants to source fibres that are native (*preferable*) with fibres that are easy to extract with minimal processing. (The plants used to make the panels photographed in this document comprise: Sun hemp, wild & domesticated Roselle , wild & domesticated Okra or Ladies Finger and Besharam grass or Bush Morning Glory)
- Harvest the plants (Refer figure 2.1)

¹ The Gramart project is a small-scaled enterprise working in the intersection of agro-ecology and art creating products that are sourced and made into finished goods locally, employing local labour and trading with care while being conscious of the whole chain of production to consumption.



Figure 2.1: Plant fibre harvesting

- Dry the harvested plants (Refer figure 2.2)



Figure 2.2: Sun drying and air drying the harvested plants

- Thresh the plants to harvest seeds for sowing during the next season (Refer figure 2.3)
- Soak the dried & de-seeded plants in water (Refer figure 2.4)



Figure 2.3: Plant threshing



Figure 2.4: Soaking threshed plant matter in water

- Manually extract fibres from the soaked plants (Refer figure 2.5)



Figure 2.5: Remove the fibrous parts from the rest of the plant

- Dry fibres after extraction (Refer figure 2.6)



Figure 2.6: Fibre drying

- Gather crop residue and wild plants that can be used to increase the binding nature of the panels, offering termite resistance, without the processing required for tough plant fibres. Cut fibres, crop residue & wild collections into small bits(Refer figure 2.7)



Figure 2.7: Cut fibres and wild plant collections into small pieces

- Make sodium carbonate (soda ash) locally by using wood ash.
- Boil the cut fibre, crop residue and wild collection pieces in sodium carbonate solution to dissolve lignin in it to make the pulp softer & brighter. (Refer figure 2.8)



Figure 2.8: Boil the fibre pieces in sodium carbonate (soda ash)

- Grind the boiled fibres to a pulp in a mixer (Refer figure 2.9)



Figure 2.9: Grind the boiled fibres to a pulp in an industrial mixer

- Make fibre panels, the measurements based on the installation site:
 - Spread the fibre pulp in a wooden mould.
 - Press the fibres to drain the water (Refer figure 2.10)



Figure 2.10: Lay out the fibres in a wooden mould within a water tank

- Press the panels to remove excess water (Refer figure 2.11)



Figure 2.1: Press the panels to remove excess water

- Sun-dry the panels (Refer figure 2.12)



Figure 2.12: Sun-dry the panels

- Label the different panels made of different raw materials appropriately (Refer figure 2.13)



Figure 2.13: Label the panels according to their raw materials

2.2.3. Wrapping the Panel with MLP

There are natural compounds and solutions available that can be applied to make the Biomass panel water and pest resistant such as Lime Plaster, Cashewnut oil, etc. However these solutions cannot single handedly address water and pest resistance, for example, cashewnut oil brings high quality of water resistance but is highly inflammable. This implies combinations of such different natural solutions need to be tried to make it full proof. In this case, in order to address this, the panels are wrapped with Multi-Layer Plastic (MLP) (Fig 2.14) sheet ensuring that shiny surface faces outside using big size stapler pins and duct tapes to give extra strength. With this the panels are ready to be installed under the roof.



Figure 2.14: Wrap the panel with shiny surface facing outside and staple it

2.2.4. Installation

- Plan the panel layout based on purlins, entrance, loft and other contextual considerations in such a way that maximum full panels are accommodated with minimum cutting of the panels and minimum joints are there and the joints come in straight lines.
- Mark the 4 walls with coloured thread indicating the line on which drilling for the support frame will happen. If using a steel alloy frame as support, choose a width that can seat the thickness of the panel, if using MS then choose an appropriate L angle (Refer figure 2.15)



Figure 2.15: MS L-angle lengths being prepared for panel support frame

- Drill and fix the support on the edge of one wall and on the opposite edge. (Refer figure 2.16)



Figure 2.16: MS L-angle drilled at a height of 14" approx(in this instance) from top of wall on all 4 walls to form the support frame

- Drill and fix the next support length according to the width of the panel. The entire installation should be in a single plane without slope. (Refer figure 2.17)



Figure 2.17: MS support frame in a single plane

- For a steel-alloy frame, get extra support from the main roof by tying steel wires in different places between the frame and a roof purlin/roof anchor (Refer figure 2.18). This is an alternative way to fix under-roof panels, however the present installation was done with support of MS framework.



Figure 2.18: Extra roof support

- Lay the panels snugly within the supports
- Measure the residue areas to figure out how many panels require cutting towards the edges of the wall after whole panels are laid. Cut the whole panels and tape the cut end with aluminium tape (Refer figure 2.19 and 2.20)



Figure 2.19: Cut the whole panel



Figure 2.20: Tape the cut end with aluminium tape

- The installation should occupy the entire space leaving no gap in the edges of walls to prevent movement of small animals.(Refer figure 2.21)



Figure 2.21 Metal support framework with panels in place with no gap in the ends

2.2.5. Maintenance

2.2.5.1. Monthly Maintenance

- Look for visible signs of discolouration, powdering of panels, wet patches and in case of leaks, remove respective panel and address the specific spot with adhesives/mortar either from under the roof or over the roof

2.2.5.2. Quarterly Maintenance

- If you find gaps have formed between the wall edge and support frame, over time, address it to ensure the gap is covered
- Look for visible signs of discolouration, powdering of panels, wet patches and in case of leaks, remove respective panel and address the specific spot with adhesives/mortar either from under the roof or over the roof

2.2.5.3. Annual Maintenance

- Check the MS supports for rusting and paint them
- If you find gaps have formed between the wall edge and support frame, over time, address it to ensure the gap is covered
- Look for visible signs of discolouration, powdering of panels, wet patches and In case of leaks, remove respective panel and address the specific spot with adhesives/mortar either from under the roof or over the roof

2.2.6. Do's and Dont's

- Do clean the roof off cobwebs from time to time
- Do not take naked flames close to the ceiling
- Do check regularly if the water is leaking from the roof cracks
- Do not keep anything inflammable in the room during the time of installation

2.3. Wood Wool Panels

2.3.1. Pre-Installation Staging

Over the roof

- Ensure that the roof is leak proof :
 - Clean the roof thoroughly to identify repair points.
 - Identify weak points such as J hooks.
 - Plug weak points with cement mortar+water proof solution.
 - The application of any sealant on a corrugated roof should not hamper smooth water flow during rains.

Under the roof

- Mark the level of the installation on the four walls, ensuring a minimum gap of 6" between roof and installation for electrical wiring/repair and 6'-6" between floor and installation and other contextual considerations such as electrical wiring, shelving, position of windows etc.
- Based on the above, rewire and reposition lights and other electrical fixtures that might hinder the installation of the panels
- Plan the panel arrangement based on entrance, loft, and other contextual considerations.
- Measure the area for the panel installation to assess how much of the panel requires cutting towards the edges of the wall after whole panels are laid.
- Remove fans before installation

2.3.2. Installation

- Mark the 4 walls with coloured thread indicating the line on which drilling for the support frame will happen
- If using a steel alloy frame as support, choose a width that can seat the thickness of the panel but if using MS then choose an appropriate L angle (Refer figure 3.1)



Figure 3.1: MS support frame for panels-installation in progress

- Drill and fix the support on the edge of one wall and on the opposite edge. Drill and fix the next support length according to the width of the panel. Try to ensure the entire installation is a single plane without slope.(Refer figure 3.2)

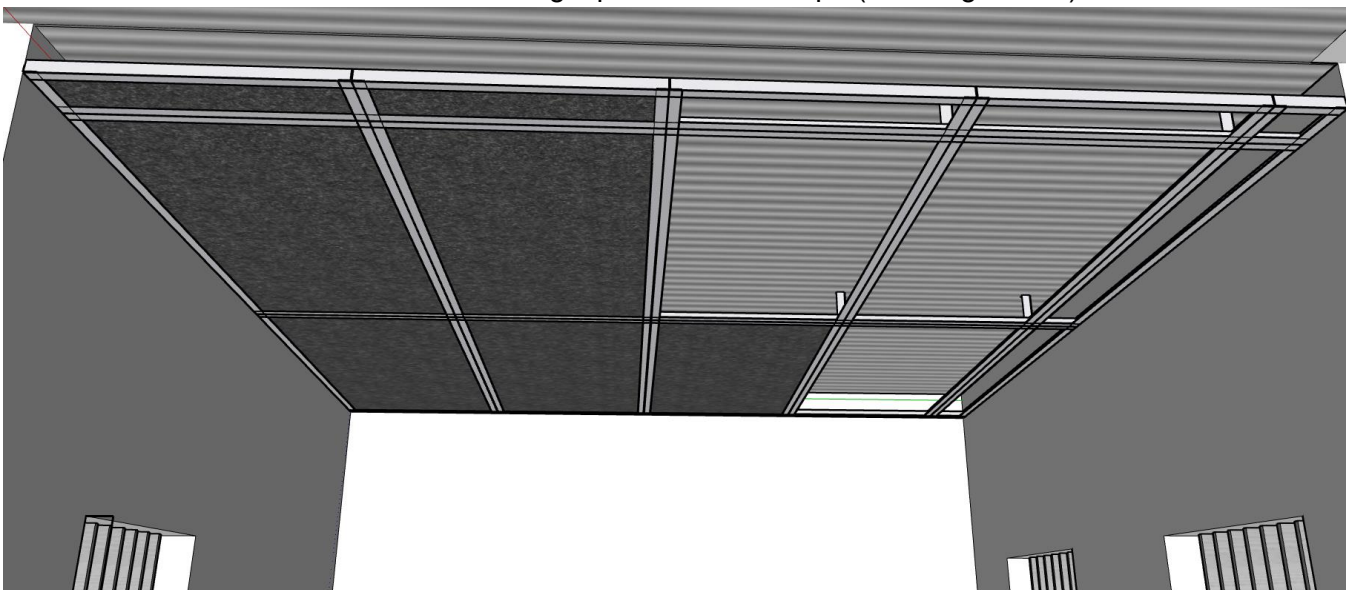

Figure 3.2: Metal frame support for panels-installation in progress

- For a steel-alloy frame, get extra support from the main roof by tying steel wires in different places between the frame and a roof purlin/roof anchor (Refer figure

3.3). This is an alternative way to fix under-roof panels, however the present installation was done with support of MS framework.



Figure 3.3: Extra roof support

- Lay the panels ensuring they sit snugly within the supports (Refer figure 3.4, 3.5, 3.6)

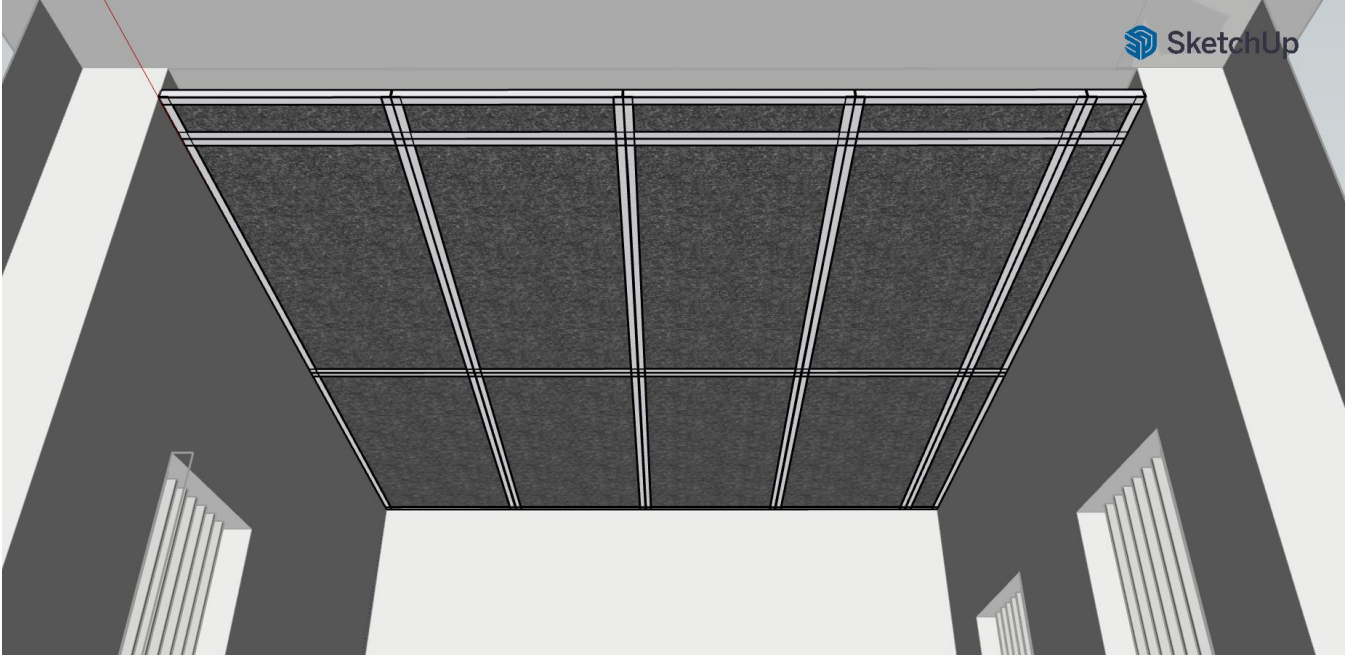

Figure 3.4: Metal support framework with panels in place



Figure 3.5: MS support framework with panels in place



Figure 3.6: Steel alloy support framework with panels in place

- Ensure the installation leaves no gap in the edges of walls to prevent movement of small animals

2.3.3. Maintenance

2.3.3.1. Monthly Maintenance

- Look for visible signs of discolouration, powdering of panels, wet patches and see if the specific panels can be removed and replaced
- In case of powdering down from the panel, apply a layer of transparent paint to the specific panels and return them to place
- In case of leaks, remove respective panel and address the specific spot with adhesives/mortar either from under the roof or over the roof

2.3.3.2. Quarterly Maintenance

- If you find gaps have formed between the wall edge and support frame, over time, address it to ensure the gap is covered
- Look for visible signs of discolouration, powdering of panels, wet patches and see if the specific panels can be removed and replaced
- In case of powdering down from the panel, apply a layer of transparent paint to the specific panels and return them to place
- In case of leaks, remove respective panel and address the specific spot with adhesives/mortar either from under the roof or over the roof

2.3.3.3. Annual Maintenance

- Check the MS supports for rusting and paint them
- If you find gaps have formed between the wall edge and support frame, over time, address it to ensure the gap is covered

- Look for visible signs of discolouration, powdering of panels, wet patches and see if the specific panels can be removed and replaced
- In case of powdering down from the panel, apply a layer of transparent paint to the specific panels and return them to place
- In case of leaks, remove respective panel and address the specific spot with adhesives/mortar either from under the roof or over the roof

2.3.4. Do's and Dont's

- Do clean the roof off cobwebs from time to time
- Do not take naked flames close to the ceiling
- Do check regularly if the water is leaking from the roof cracks
- Do not keep anything inflammable in the room during the time of installation

2.4. Rooftop Garden

2.4.1. Pre-Installation Staging

- Ensure That The Roof Is Leak Proof (Waterproofing)
 - Clean the roof thoroughly to identify repair points.
 - Identify weak points such as J hooks. Plug weak points with cement mortar+water proof solution.
 - The application of any sealant on a corrugated roof should not hamper smooth water flow during rains.
- Make a Walkable Parapet Wall
 - Inspect the parapet wall and repair any damaged or weak areas.
 - Make the parapet wall safe for walking by increasing the width to at least one foot by masonry activity (refer figure 4.1).



Figure 4.1: Parapet wall after repair works

- If the parapet is at different heights (owing to the slope), then make a raised platform with bricks equal to the width of the bamboo frame, to have an equal level to place the bamboo frame (refer figure 4.2).



Figure 4.2: Bamboo frames kept over raised platform

- Ensure an easy access to roof
 - Use a sturdy ladder to access the roof.

- Ensure access to Water on the Roof - Includes Installation Pump Set and Overhead Tank
 - Determine if the roof can support the weight of a water tank.
 - Get the household's approval to install the tank to ensure everyone is on board with it.
 - Evaluate and procure materials for the necessary masonry, plumbing, and electrical works required to support the tank's installation.
 - Carry out the necessary works, including masonry, plumbing and electrical works.
 - Once all necessary works are complete, install the water tank on the roof, ensuring it is safely and securely in place (refer figure 4.3).



Figure 4.3: Over Head Tank After Installation

- Make sure that all raw materials are on site before installation
 - Prepare the potting mix at least 21 days before planting or sowing. Include manure such as cow dung, vermi-compost, cocopeat, perlite for better fertility. In case of paucity of time, market available potting mix can also be procured.
 - Procure growbags or pots suitable for rooftop planting.
 - Procure irrigation materials, fabricated bamboo frames and trellis.
 - Prepare or purchase saplings based on the planting plan.

2.4.2. Fabrication

- Make Bamboo Frames For Keeping The Growing Pots/Container
 - Cut the 2" diameter bamboo poles as per the required length
 - Attach five poles with 2" distance between each other with pattsis and make sure that use one patti every 18" length (refer figure 4.4).
 - Make bamboo frame as per the required number



Figure 4.4: Bamboo Frame After Fabrication

- Make Bamboo Trellis To Support Vegetative Cover
 - Cut the bamboo strips as per the measurement of required trellis.
 - Then arrange the strips to all direction like fishing net.
 - Attached strips with GI binding wire (refer figure 4.5)



Figure 4.5: Fabrication of Bamboo Frame for Trellis

2.4.3. Installation

- Laying The Bamboo Frame
 - Lay the bamboo frames perpendicular marked spots of parapets
 - Make sure there is no height difference between both end
 - Make sure that stands are sitting well (refer figure 4.6).



Figure 4.6: Installation of Bamboo Frames

- Lay The Grow Pots/Containers
 - Make sure the equal distancing of each pots
 - Fill the growbags evenly with the potting mix, ensuring proper distribution across all sides.
 - Maintain a soil depth of 4–6 inches in each bag for effective plant growth. (refer figure 4.7)



Figure 4.7: Filling Of Potting Mix In The Growing Pot

- Lay The Irrigation Pipeline
 - Cut the 16 mm drip lateral pipe as per the required length.
 - Attach with elbow and 'T' joiner wherever required.
 - Stretch hose pipe before attaching to the bamboo frame (refer figure 4.8)



Figure 4.8: Stretching of Irrigation Hose for Installation

- Then connect the drip pipe with a float valve (passive wicking unit). Use micro-tube for this (refer figure 4.9).



Figure 4.9: Float Valve Box Attached with Irrigation Hose and Pot

- Run the water to check whether the microtube and float valve is working or not. (refer figure 4.10)



Figure 4.10: Checking The Consistency Of Water Flow

- If it is working then assemble the rest of the part to the box, then make sure that the wicking thread is wet before burying it in the pots.
- Make sure that thread is completely submerged in the soil.
- Attach floating valve for each pots after primary checking.
- Run the entire system before planting and check for moisture ingress into the soil (refer figure 4.11).



Figure 4.11: Burying The Float Valve In Potting Mix

- Arrange the trellis and supporting sticks
 - Take a pair of bamboo frames or panels. Connect the top part of the frame using zip ties or other fasteners to form a triangular shape.
 - Position the triangular bamboo frames on over horizontal bamboo frames.
 - Ensure the vertical frames are securely placed on the stands and locked in place using zip ties or other fasteners (refer figure 4.12).



Figure 4.12: Assembling The Bamboo Trellies Together

- Arrange the trellis system in close proximity to the growing containers or planting areas. This will allow the plants to climb easily and utilize the trellis for support to grow.
- Construct and arrange other pairs of bamboo frames in a similar manner to create a comprehensive trellis system.
- Ensure the entire trellis structure is stable, secure, and positioned appropriately for the plants' growth (refer figure 4.13).



Figure 4.13: Assembling Of Bamboo Trellises

- Spread The Garden Net On Top Of Trellis
 - Cut the net as per the size of trellis; as good practice, cut an extra foot.
 - Fold the net length then gently place the middle part of the net on top of trellis.
 - Make sure that net is covered with each corner of the trellis and not stuck anywhere.
 - Tie the top part well with zip tag and each corner little loose, such that it can be adjusted in future if required (refer figure 4.14)



Figure 4.14: Attaching The Garden Net To The Bamboo Trellises

- Planting and Arranging the Grow Containers
 - Ensure the grow containers have a moist soil environment through the use of wicking irrigation.
 - If the seeds are ready to plant, soak them (especially gourd seeds) for at least four hours before planting (refer figure 4.15)
 - Plant the soaked seeds in a corner close to the trellis.
 - Sow the seeds at a maximum depth of 2 inches (refer figure 4.16).



Figure 4.15: Sowing of Soaked' Seed In The Pot

- If ready-to-plant saplings are available for planting, position them in a corner close to the trellis.
- Plant bushy plants like chili and eggplant in the middle or non-trellis side of the grow containers.



Figure 4.16: Sowing of 'Soaked' Seed In The Pot

- Include at least one bean family plant in each grow container.
- Maintain a minimum distance of 6 inches between each plant.
- Mulch the pots with dry biomass like sugarcane bagasse, dry leaves, etc (refer figure 4.17).



Figure 4.17: Mulching The Pot After Seed Sowing



Figure 4.18.1: Rooftop Garden After Installation



Figure 4.18.2: Rooftop Garden After Installation

2.4.4. Maintenance

2.4.4.1. Monthly Maintenance

- Ensure active climbing plants like gourds, cucumbers, and pole beans are in pots and trained towards the trellis.
- In case of dryness for prolonged duration in the soil, inspect the irrigation system for any blockages or issues.
- If any blockages are noticed, promptly remove them to maintain proper water flow.
- Every 10 days, add compost, *jeevamrita*, or other organic inoculants to the potting mix.
- Visually inspect the bamboo frames and trellis structure for any signs of discoloration or damage.
- If any issues are noticed, perform the necessary tying, adjustments, or replacements to keep the system in good condition.

2.4.4.2. Quarterly Maintenance

- Visually inspect the bamboo frames and trellis structure for any signs of discoloration or damage.
- If any issues are noticed, perform the necessary tying, adjustments, or replacements to keep the system in good condition.
- Identify any overly grown or mature plants in the system. Carefully remove these plants and replace them with new, healthy plants.
- When planting the new plants, add a handful of compost to the grow containers to replenish the soil nutrients.
- Check the micro-tubes in the irrigation system for any blockages or salt accumulation. If any blockages are noticed, replace the affected micro-tubes to ensure uninterrupted water flow.

2.4.4.3. Annual Maintenance

- Check the micro-tubes in the irrigation system for any blockages or salt accumulation. If any blockages are noticed, replace the affected micro-tubes to ensure uninterrupted water flow.
- Carefully inspect the bamboo frames and trellis to identify any areas that are damaged or compromised. Replace Damaged Carefully remove the damaged bamboo frames or trellis sections. Replace them with new, sturdy bamboo or alternative materials as needed. Ensure Structural Integrity: When installing the new components, make sure they are properly secured and integrated into the existing system. Adjust and reinforce the connections to maintain the overall structural integrity of the trellis and support system.

2.4.5. Do's and Dont's

- Regularly remove any dry leaves, debris, or other materials from the space between the rooftop and the garden settings.
- Maintain a clean and unobstructed environment to allow for proper air circulation and water flow.
- Promptly address any signs of water leakage or restricted water movement in the system.
- Identify and resolve the underlying causes to ensure efficient water distribution and drainage.
- During periods of excessive summer heat, monitor the moisture levels in the grow containers.
- In case reduced moisture despite the wicking irrigation system, supplement by manually sprinkling some water onto the pots.

2.5. Water Filled PET Bottles

2.5.1. Pre-Installation Staging

- Ensure that the roof is cleaned thoroughly. (Refer figure 5.1)



Figure 5.1: Cleaning Of Roof

2.5.2. Fabrication

- Fill the one litre PET bottle with water. Ensure that the bottles are free of cracks, dents and also leakproof. (Refer figure 5.2)



Figure 5.2: Filling Of PET Bottles

- Cut MS strip to match the width of the roof. This strip will act as holding guards and prevent the bottles from sliding down (Refer figure 5.3)



Figure 5.3: Cutting Of MS Strip

- Fabricate MS angles for the roof edge to function as a support frame. Ensure the angle provides a slight overhang beyond the roof edge.

2.5.3. Installation

- Apply adhesive (Heat X) over the roof to ensure the Silpaulin bonds firmly with the roof (Refer figure 5.4)



Figure 5.4: Applying Of Adhesive Over The Roof

- Stick Silpaulin across the roof, ensuring it aligns with the corrugation pattern (Refer figure 5.5)



Fig 5.5: Sticking Of Silpaulin Across The Roof

- Press the Silpaulin firmly to eliminate air pockets and allow the adhesive to set. Ensure there is no lifting or folding.



Figure 5.6: Final View After Application Of Silpaulin

- Apply adhesive (Heat-X) only to the base of each PET bottle (the part that will touch the roof), not on the sides or top (Refer figure 5.7)



Fig 5.7: Application Of Adhesive Along The Bottle Side Which Touches The Roof

- Place the adhesive applied bottles in the trough of the roof with equal spacing. (Refer figure 5.8)



Figure 5.8: Placing Of Bottles In The Trough Of Roof With Equal Spacing



Figure 5.9: Final View After Placing Of PET Bottles

- Once all bottles are placed, secure the MS strips across the roof to hold the bottles in place. (Refer figure 5.10)



Figure 5.10: Securing Of MS Strip Through Welding



Figure 5.11: Final View After MS Strip Installation

2.5.4. Maintenance

2.5.4.1. Monthly Maintenance

- Ensure PET bottles are in place and have not shifted due to wind, rain, or vibrations.
- Verify bottles are still firmly attached to the silpaulin.
- Lightly clean bottles and crates to prevent algae, dirt, or moss buildup.

2.5.4.2. Quarterly Maintenance

- Check for wear, small tears, or loosening of adhesive or sealing material. Repair if needed.
- Make sure no stagnant water is collected around bottles, which can attract mosquitoes.

2.5.4.3. Annual Maintenance

- Remove all bottles, clean them thoroughly, and wash the silpaulin surface.
- Replace PET bottles that are discolored or have lost strength.
- Check if the silpaulin sheet has weakened. Replace if degraded.

2.5.5. Do's and Dont's

- Use clear, good-quality PET bottles with caps tightly closed.
- Keep bottles completely filled with water for maximum heat absorption.
- Conduct extra checks after heavy rain, storms, or high wind.
- Don't use bottles that are already brittle or weak as they can crack under heat.
- Don't overload one section of the roof i.e. distribute bottles evenly.

2.6. Water Filled PET Bottles In Crates

2.6.1. Pre-Installation Staging

Over the roof

- Ensure that the roof is cleaned thoroughly (Refer figure 6.1)



Figure 6.1: Cleaning Of Roof

2.6.2. Fabrication

- Fill the 1 litre PET bottle with water. Ensure that the bottles are free of cracks, dents and also leakproof. (Refer figure 6.2)



Figure 6.2: Filling Of Water In Pet Bottles

2.6.3. Installation

- Apply a small amount of adhesive (Heat-X) to ensure the Silpaulin bonds firmly with the roof. (Refer figure 6.3)



Figure 6.3: Applying Of Adhesive Above The Roof

- Place the Silpaulin sheet evenly across the roof. (Refer figure 6.4)



Figure 6.4: Placing Of Silpaulin Above Roof

- Take each crate and align accordingly above the Silpaulin, ensuring they are firmly positioned (Refer figure 6.5)



Figure 6.5: Placing Of Crates Above Roof

- Once the crates are positioned, lay the MLP sheet over the crates. Ensure that the reflective (shiny) side of the MLP sheet is facing downward, towards the roof, to provide a low emissivity surface (Refer figure 6.6)



Figure 6.6: Placing Of MLP Sheets Inside The Crate

- Place the water-filled 1 litre PET bottles into the crates in two layers: The first layer should be placed side by side at the bottom. The second layer should be staggered, meaning each bottle sits in the gap between the bottles in the first layer, forming an interlocking pattern as shown in the Figure 6.7.



Figure 6.7: Placement Of Bottles In Crates (Second Layer Sits In The Gap Of First Layer)

- Repeat the above steps for all crates until the entire roof surface is covered uniformly.
- If the roof slope is steep and there's a risk of the crates sliding down, install MS (Mild Steel) strips along the roof edge to keep the crates securely in place as described in section 2.5.2 (refer figure 5.10)



Figure 6.8: Final Placement Of Pet Bottle In Crates

2.6.4. Maintenance

2.6.4.1. Monthly Maintenance

- Ensure crates and PET bottles are in place and have not shifted due to wind, rain, or vibrations.
- Look for any PET bottles that are punctured, cracked, or leaking water. Replace if needed.
- Lightly clean bottles and crates to prevent algae, dirt, or moss buildup.

2.6.4.2. Quarterly Maintenance

- Ensure waterproofing sheets remain intact, with no peeling, tears, or displacement.
- Recheck alignment of crates, especially on sloped roofs, and re-secure if any slippage is noticed.

2.6.4.3. Annual Maintenance

- Empty and clean all crates and bottles thoroughly to remove dust, algae, or sediment.
- Replace PET bottles showing discoloration or deformation.
- Check plastic crates for cracks or warping. Replace the damaged crates.

2.6.5. Do's and Dont's

- Keep bottles filled to capacity to ensure proper thermal performance.

- Conduct inspections after heavy rain or strong winds
- Don't overload the roof - stick to recommended load-bearing capacity.
- Don't skip periodic checks.

2.7. Space Frame

2.7.1. Pre-Installation Staging

A. Supports:

- Depending on the decision, number of supports - single legs or double legs with metal sections need to be cast separately.

B. Placement and Design Decisions :

- Determine the orientation and length of the fractals

C. Removal of any objects :

- The roof needs to be cleared of any objects or sheets and thoroughly scrubbed with wire brush at locations where the concrete base would be adhered.

2.7.2. Fabrication

A. Wood work:

Figure 7.1: Wooden shuttering with GD clamp

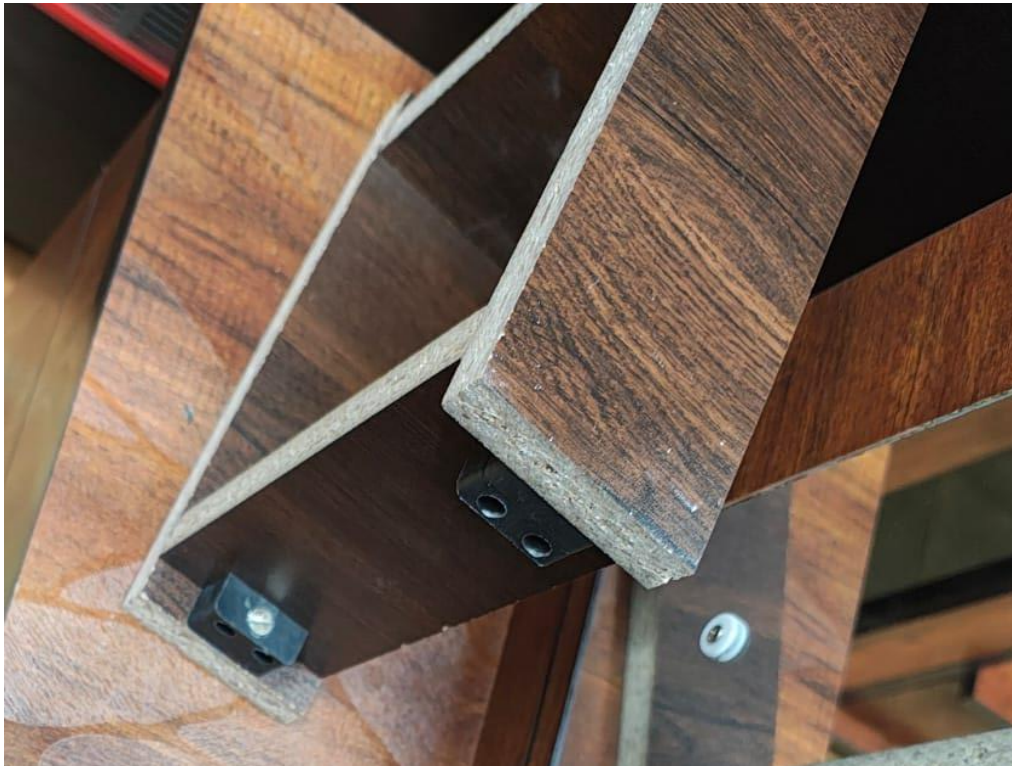

B. Metal work:



Figure 7.2: Supports at the base

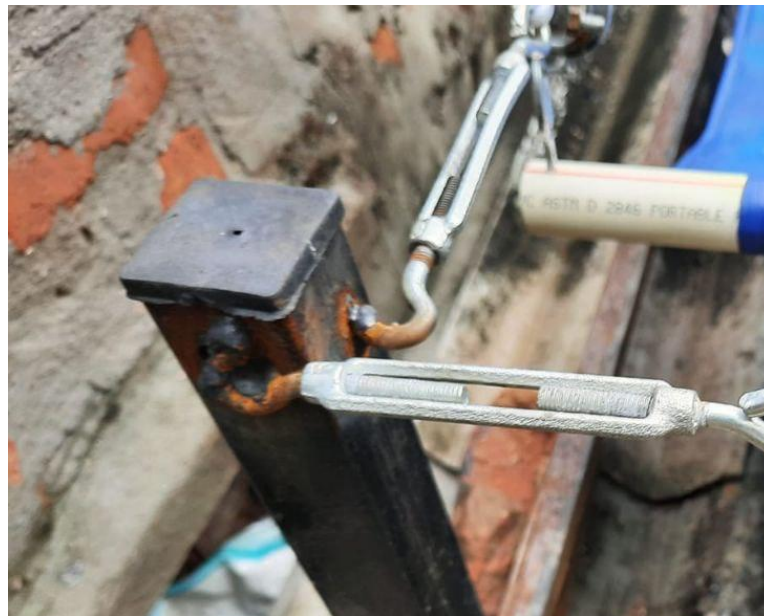

Figure 7.3: Hooks welded at adjacent faces of the box section



Figure 7.4: Painting of Box Sections

C. Masonry work:

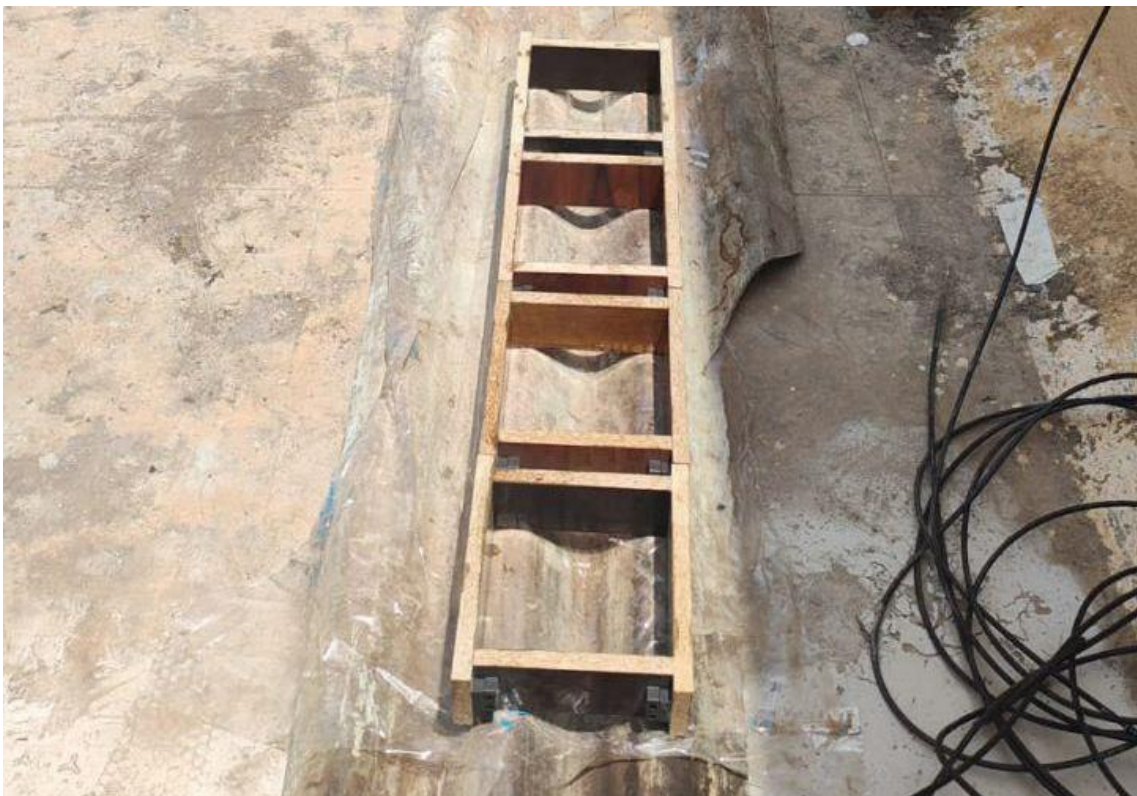

Figure 7.5: Placing of moulds on roofing sheet

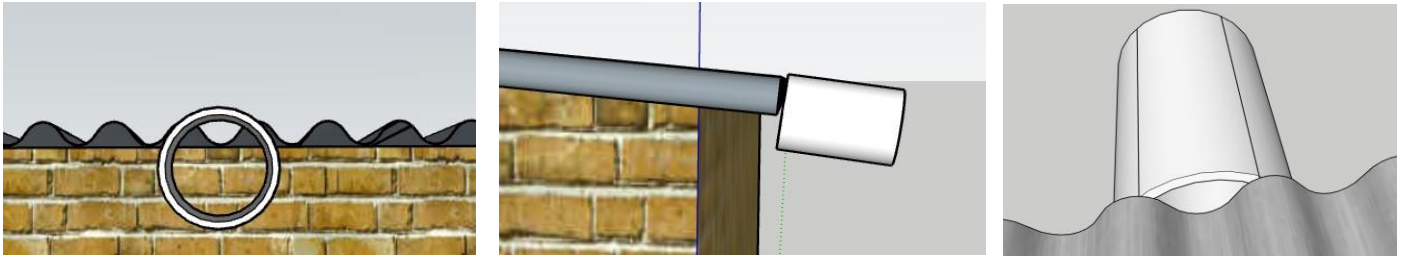

Figure 7.6: Placing of PVC pipe

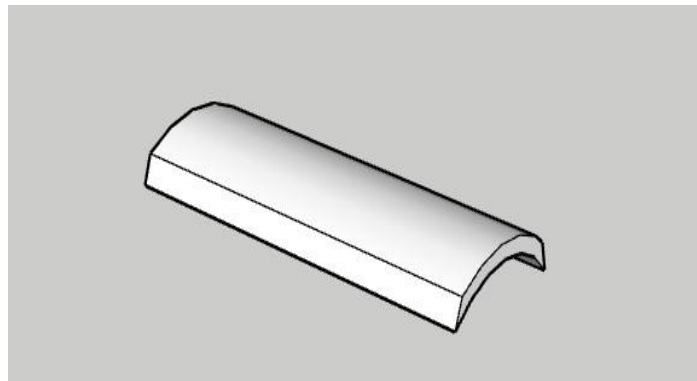

Figure 7.7: Placing of PVC pipe



Figure 7.8: Casting the support with drip line

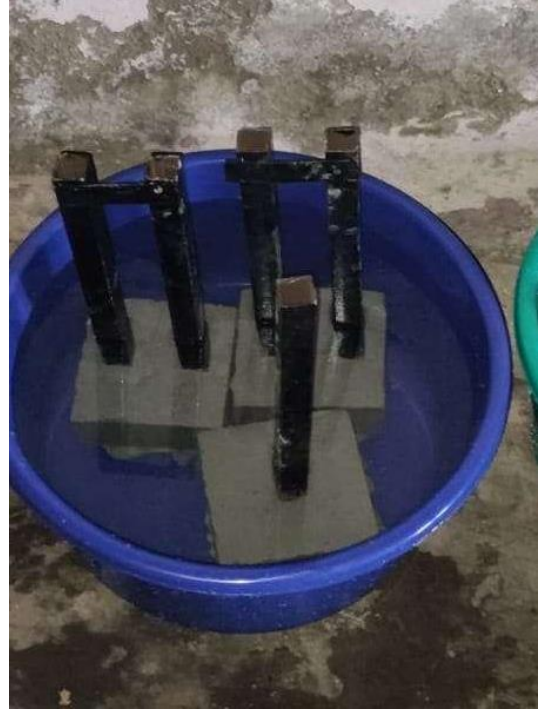

Figure 7.9: Curing the cast

D. Tailoring work:

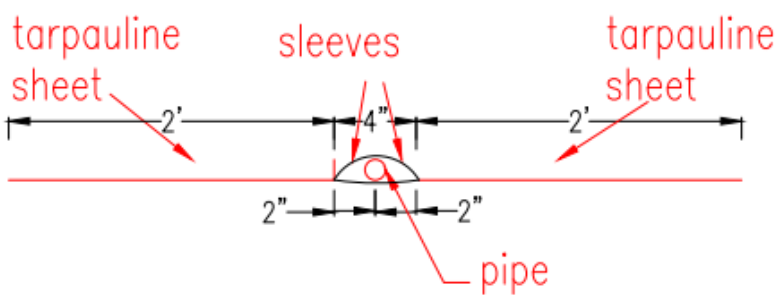
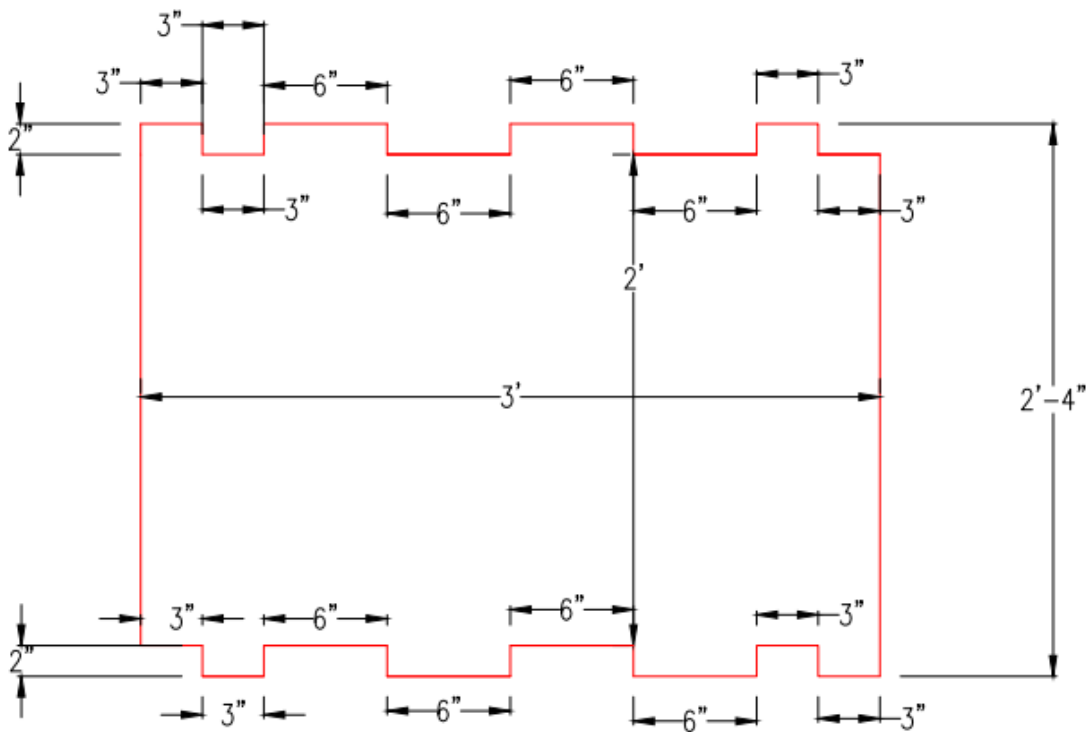
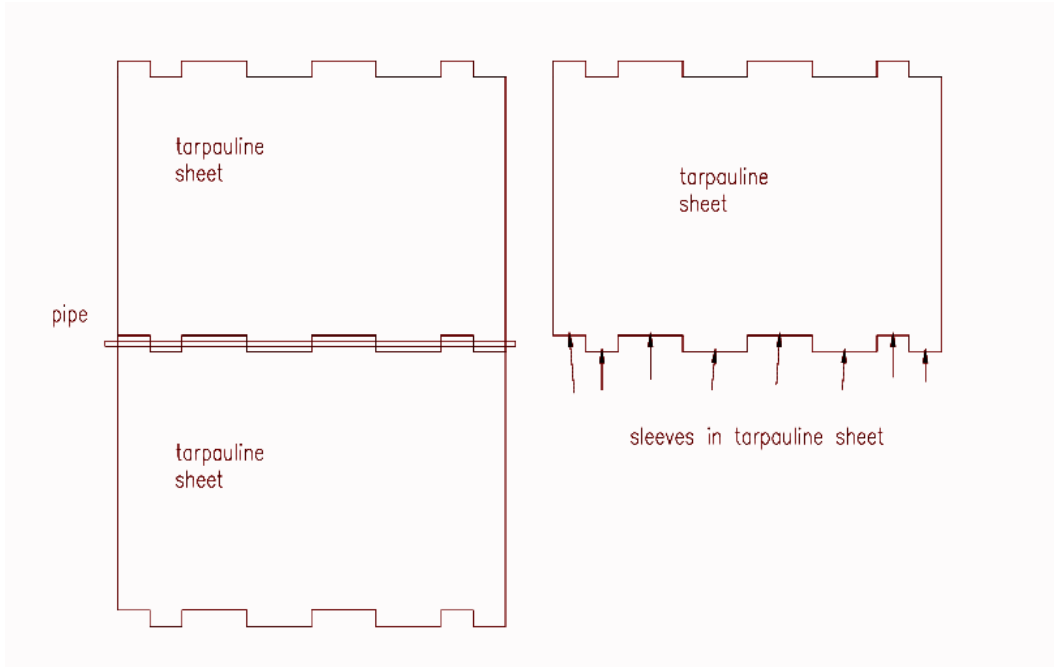

Figure 7.10: Drawing of Stitching



Figure 7.11: Attaching MLP to Tarpaulin

E. PVC Pipe Work:



Figure 7.12: Marking of points to attach hooks.



Figure 7.13: Attaching hooks.

F. Curtain Assembly Work:



Figure 7.14: Inserting intermediary PVC pipes to make the fractal.



Figure 7.15: Welding washer to metal curtain rings

2.7.3. Installation



Figure 7.16: Hooking up fractals to curtain rings

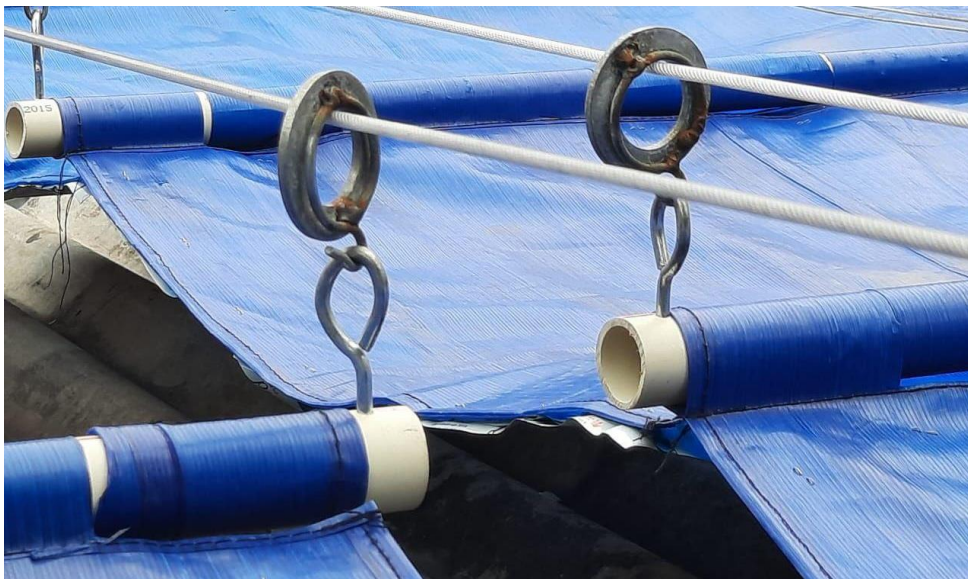

Figure 7.17: Hooking up fractals to curtain rings



Figure 7.18: Placement of pulleys on front and rear end of the fractal along with handling mechanism

2.7.4. Operation

- Similar to the Internal Dynamic Barrier, when you pull one end of the handling wire, the fractal opens and vice-versa.
- Tug at the nylon wire with uniform gentle force and not spurts of violent force.
- In case any resistance is observed, kindly pull back in the opposite direction and retry.

2.7.5. Maintenance

2.7.5.1. Monthly Maintenance

None

2.7.5.2. Quarterly Maintenance

- Grease the PVC coated steel wires, over which the Dynamic Barrier slides, every quarter.
- Introduce tension into the system by tweaking at the tension fastener, as and when any sag is observed in the fractal.

2.7.5.3. Annual Maintenance

- Check for any rupture on the Low-emissivity barrier and replace the particular fractals if necessary.

2.7.6. Do's and Dont's

- Ensure the roofing sheets to which base is being adhered to is properly attached to the structure.
- Use only slow setting Araldite.

2.8. Vertical Bamboo Blind

2.8.1. Pre-Installation Staging

- Divide the wall area to be covered into segments where the openings (doors and windows) are present 'vs' where they aren't.
- Delineate the segments where the openings aren't present, is where the dynamic barrier should be fabricated. (Refer figure 8.1)



Figure 8.1: Delineating the Dynamic(white) and Static components(pink)

- The spaces above and below the window, as well as above the door are to be designated for static barriers.
- Check for any possibility of pre-existing truss or member near the roof overhang, so the barriers can be suspended directly from them. If yes, please test if the member can take the load of the Bamboo Blind. If not, we will have to take supports from the wall by driving anchor bolts.

2.8.2. Fabrication

A. Preparation of Vertical Barrier:

- The width of the dynamic barrier shall be taken as the distance between the openings(door and window) and one of the openings to the edge of the wall. Consider 4 feet to be the maximum width of each fractal. Employ a second fractal in case of larger widths.
- For the length, avoid considering the entire wall height and limit it to 1.5 feet less than the wall height. We will place the Vertical Barrier in the middle of the wall and not to either extreme. If the Cane Blind is touching the ground, it is prone to faster decomposition.
- For the width of the static barrier, take it 6” less than the actual span of the opening. This is to provide a buffer between adjacent fractals to facilitate dynamic movement.
- Order for the manufacturing of Bamboo Blinds with the said dimensions. Cut 4 MLPs each equal to the size of manufactured Bamboo Blinds in width and 6 inches longer than the length of the Cane Blind.
- Adhere MLPs to the Bamboo Blind, using the zip tag ties as we did for the Internal Dynamic Barrier in the middle.

- Put a duct tape over the edges and staple(8-10mm) the shorter edges to Bamboo stick at top and bottom along the length.(Refer figure 8.2)



Figure 8.2: Stapling of MLP sheets on primary bamboo section

B. Establishing Supports:

- If there is an existing overhang purlin, which can take the load of a Vertical Barrier, utilise it to hang the Vertical Barrier. (Refer figure 8.3)

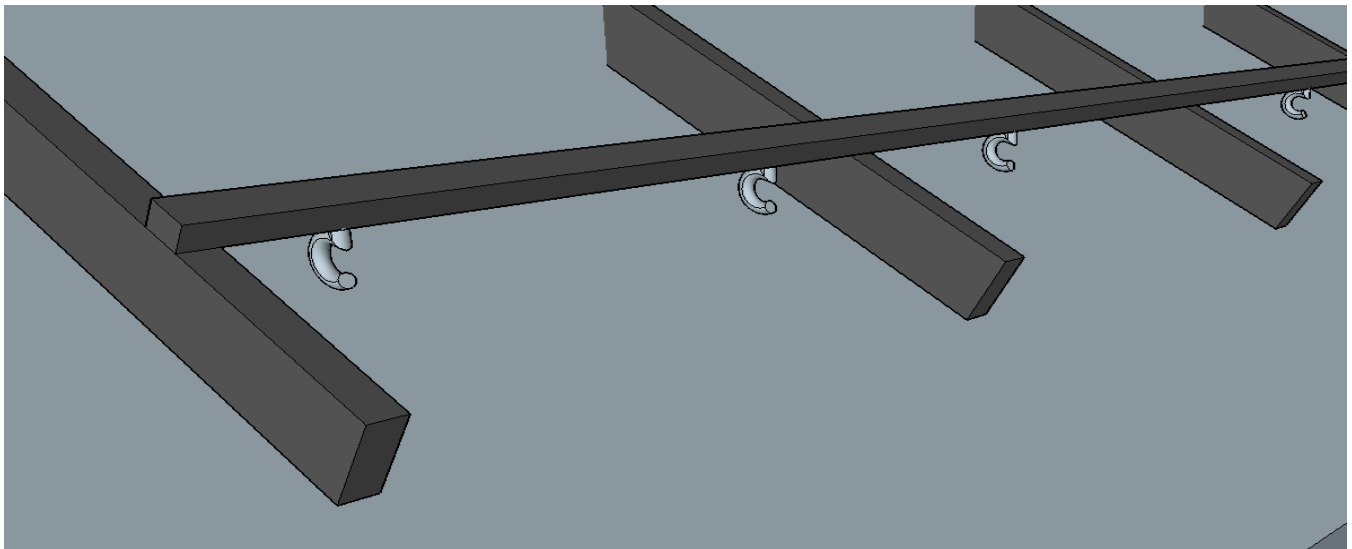

Figure 8.3: Fabrication of supports for Vertical Barrier (variant 1)

- In case that isn't available, drill holes to the wall at a level from where measurements were taken from.
- Follow the same pattern of support positions as that of Internal Dynamic Barrier - 5 inches from either end and one at the mid point - 3 supports per fractal.

- Ensure there is at least a buffer of 6 inches between adjacent fractals to facilitate easy rolling and unrolling (Refer figure 8.4)



Figure 8.4: 6-inch buffer between adjacent installations

2.8.3. Installation

- With a help of a Galvanised Iron wire tie the topmost Bamboo section to the hooks.
- Ensure the rolling is happening to the outer side. (Refer figure 8.5)

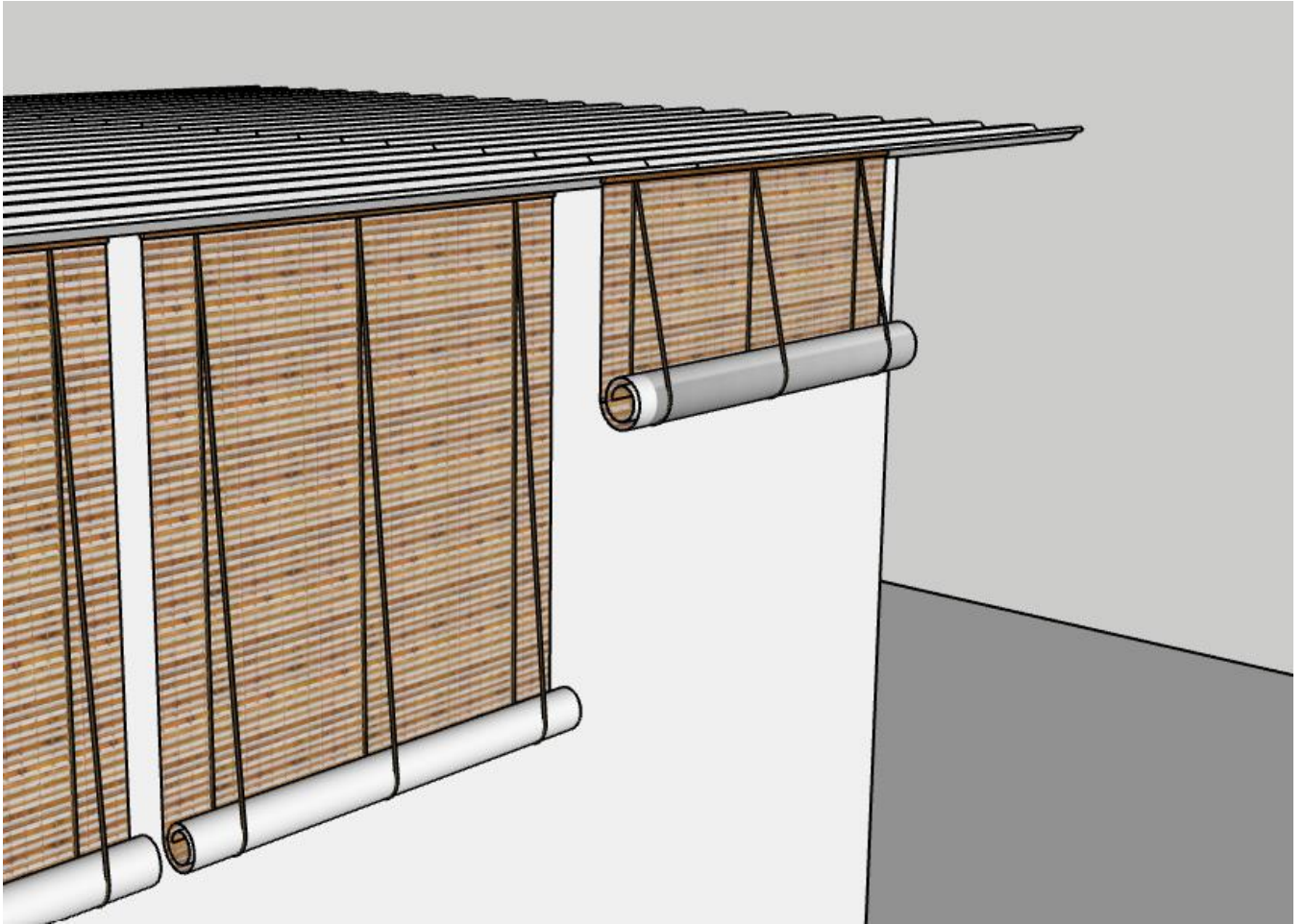

Figure 8.5: Rolling of the Vertical Barrier to the outside

2.8.4. Operation

- The Vertical Barrier is to be opened before 8 am, shielding the structure from direct sunlight.
- By sunset, about 6pm, the barrier can be rolled up, so that the walls/ structure is exposed to night sky radiation.

2.8.5. Maintenance

2.8.5.1. Monthly Maintenance

- Use a dry and soft cloth to clean the shiny surface of the installation.

2.8.5.2. Quarterly Maintenance

- Check if there have been any ruptures to the Multi-Layer Plastic sheet caused by abrasion or anything else.

2.8.5.3. Annual Maintenance

- Check for signs of oxidation at the Galvanised Iron wires, using which the Bamboo section has been suspended.

2.8.6. Do's and Dont's

- While stapling, keep the axis of stapler perpendicular to the Bamboo Stick. Having them on the same axis longitudinally will split the Bamboo.
- While inserting the primary bamboo section into the hook supports established, ensure that the movement of handling rope isn't being hindered.
- During the rainy season, it is advisable to keep opening the Vertical Barrier intermittently to let off water which might have gotten logged within the fractal. This is to help discourage mold formation due to water logging.

Environmental Sustainability Report

Thermic SEEDS, Delhi

Table of Contents

1. Rooftop Gardening	4
1.1. Environmental Impacts	4
1.1.1. Negative Environmental Impacts	4
1.1.2. Positive Environmental Impacts	7
1.1.3. Summary	9
1.1.3.1. Overall Evaluation of Positive & Negative Impacts	9
1.1.3.2. Potential for Unintended Consequences	9
1.1.3.3. Further Research Needs	10
1.2. Socio-Economic Impacts	10
1.2.1. Negative Socio-Economic Impacts	10
1.2.2. Positive Socio-Economic Impacts	11
1.2.3. Summary	12
1.2.3.1. Overall Evaluation of Positive & Negative Impacts	12
1.2.3.2. Potential for Unintended Consequences	12
1.2.3.3. Further Research Needs	12
2. PET Bottles	13
2.1. Environmental Impacts	13
2.1.1. Negative Environmental Impacts	13
2.1.2. Positive Environmental Impacts	15
2.1.3. Summary	17
2.1.3.1. Overall Evaluation of Positive & Negative Impacts	17
2.1.3.2. Potential for Unintended Consequences	18
2.1.3.3. Further Research Needs	18
2.2. Socio-Economic Impacts	18
2.2.1. Negative Socio-Economic Impacts	18
2.2.2. Positive Socio-Economic Impacts	19

2.2.3. Summary	20
2.2.3.1. Overall Evaluation of Positive & Negative Impacts	20
2.2.3.2. Potential for Unintended Consequences	20
2.2.3.3. Further Research Needs	20
3. Multi-Layered Plastic (MLP)	20
3.1. Environmental Impacts	20
3.1.1. Negative Environmental Impacts	21
3.1.2. Positive Environmental Impacts	22
3.1.3. Summary	24
3.1.3.1. Overall Evaluation of Positive & Negative Impacts	24
3.1.3.2. Potential for Unintended Consequences	24
3.1.3.3. Further Research Needs	24
3.2. Socio-Economic Impacts	24
3.2.1. Negative Socio-Economic Impacts	25
3.2.2. Positive Socio-Economic Impacts	25
3.2.3. Summary	26
3.2.3.1. Overall Evaluation of Positive & Negative Impacts	26
3.2.3.2. Potential for Unintended Consequences	27
3.2.3.3. Further Research Needs	27
4. Biomass Panels	27
4.1. Environmental Impacts	27
4.1.1. Negative Environmental Impacts	27
4.1.2. Positive Environmental Impacts	29
4.1.3. Summary	32
4.1.3.1. Overall Evaluation of Positive & Negative Impacts	32
4.1.3.2. Potential for Unintended Consequences	32
4.1.3.3. Further Research Needs	32
4.2. Socio-Economic Impacts	32

4.2.1. Negative Socio-Economic Impacts	32
4.2.2. Positive Socio-Economic Impacts	33
4.2.3. Summary	34
4.2.3.1. Overall Evaluation of Positive & Negative Impacts	35
4.2.3.2. Potential for Unintended Consequences	35
4.2.3.3. Further Research Needs	35
5. Wood Wool Panel	35
5.1. Environmental Impacts	35
5.1.1. Negative Environmental Impacts	35
5.1.2. Positive Environmental Impacts	37
5.1.3. Summary	39
5.1.3.1. Overall Evaluation of Positive & Negative Impacts	39
5.1.3.2. Potential for Unintended Consequences	39
5.1.3.3. Further Research Needs	40
5.2. Socio-Economic Impacts	40
5.2.1. Negative Socio-Economic Impacts	40
5.2.2. Positive Socio-Economic Impacts	41
5.2.3. Summary	41
5.2.3.1. Overall Evaluation of Positive & Negative Impacts	42
5.2.3.2. Potential for Unintended Consequences	42
5.2.3.3. Further Research Needs	42

1. Rooftop Gardening

This solution includes materials like bamboo (for trellis, pot supports), PVC pipes, PE pipes (drip irrigation pipes), HDPE plastics (pots, water drum), and Natural materials (soil, compost, cocopeat, perlite)

1.1. Environmental Impacts

1.1.1. Negative Environmental Impacts

Table 1: Negative Environmental Impacts - Rooftop Gardening

Life Cycle Stage / Environmental Impact Category	(1) Global Warming / Climate Change/Air Pollution	(2) Acidification	(3) Eutrophication (Terrestrial / Aquatic)	(4) Combined Toxicity (Human Health, Fresh water, Terrestrial and Marine)	(5) Photochemical oxidant formation	(6) Land Use	(7) Ozone Depletion	(8) Resource Depletion - Water, Energy	(9) Resource Depletion- Mineral, Fossil Renewables.	(10) Solid Waste
Raw Material Acquisition	A significant amount of GHG gases is released during the extraction and	None	None	None	None	None	None	None	None	None

	manufacturing of the HDPE/PE-based plastic materials.									
Manufacturing	None	None	None	None	None	None	None	None	None	None
Distribution/Transportation	None	None	None	None	None	None	None	None	None	None
Use/Reuse/Maintenance	None	None	None	Microplastic release from the use of plastic pipes, drums, and pots is to be researched	None	None	None	Watering of plants could be an issue if there's water scarcity in summer	Use of electricity to pump the water from the ground to the overhead tank	None
End-of-Life	None	None	None	Incineration of the plastic materials leads to the release of pollutants like dioxin, furan, sulfur oxides (SOx), posing a risk to human	None	The plastic materials may end up as debris in the landfill	None	None	None	Plastic pipes, pots

				<p>health and are hazardous to both land and sea environments. Plastic pollution and microplastics are found in drinking water, freshwater¹ and the environment². Chemicals used in plastics are found to be present in the human population, and plastic debris is ingested by wildlife³</p>						
--	--	--	--	--	--	--	--	--	--	--

¹ Microplastics in drinking-water. Geneva: World Health Organization; 2019. Licence: CC BY-NC-SA 3.0 IGO

² Sustainability Life Cycle Environmental Impacts of PET Plastic Water Bottles. (n.d.). Nems.nih.gov. <https://nems.nih.gov/sustain/Pages/PETWaterBottleImpact.aspx>

³ Thompson, R. C., Moore, C. J., vom Saal, F. S., & Swan, S. H. (2009). Plastics, the environment and human health: current consensus and future trends. *Philosophical Transactions of the Royal Society B: Biological Sciences*, 364(1526), 2153–2166. <https://doi.org/10.1098/rstb.2009.0053>

1.1.2. Positive Environmental Impacts

Life Cycle Stage / Environmental Impact Category	(1) Global Warming / Climate Change/Air Pollution	(2) Acidification	(3) Eutrophication (Terrestrial / Aquatic)	(4) Combined Toxicity (Human Health, Fresh water, Terrestrial and Marine)	(5) Photochemical oxidant formation	(6) Land Use	(7) Ozone Depletion	(8) Resource Depletion - Water, Energy	(9) Resource Depletion- Mineral, Fossil Renewables	(10) Solid Waste
Raw Material Acquisition	None	None	None	None	None	None	None	None	None	None
Manufacturing	None	None	None	None	None	None	None	None	None	None
Distribution/Transportation	None	None	None	None	None	None	None	None	None	None
Use/Reuse/Maintenance	Rooftop gardening provides thermal comfort by employing passive cooling principle ie., soil in the pot	No use of chemical fertilizers	No use of chemical fertilizers	The harvest is organically grown	None	None	None	Rooftop gardening provides thermal comfort by employing passive cooling principle ie., thermal	None	None

	<p>functions as thermal mass, foliage of living vegetation shields the roof from direct solar radiation (shading) and evaporation of water from the soil and foliage produces an adiabatic (evaporative) cooling effect stemming from the significant latent heat of evaporation of water, with little use of electricity (for pumping water to the overhead tank) than the conventional cooling devices. Cooling is achieved without the use of any refrigerants</p>							<p>mass, shading, and evaporation, with minimal use of electricity for pumping the water to the overhead tank. Hence, it uses less electricity as compared to conventional cooling devices.</p>		
--	---	--	--	--	--	--	--	---	--	--

	that have high GWP. Growing plants helps improve air quality.									
End-of-Life	None	None	None	None	None	None	None	None	None	None

1.1.3. Summary

1.1.3.1. Overall Evaluation of Positive & Negative Impacts

Rooftop gardening provides thermal comfort by employing passive cooling principle ie., soil in the pot functions as thermal mass, foliage of living vegetation shields the roof from direct solar radiation (shading) and evaporation of water from the soil and foliage produces an adiabatic (evaporative) cooling effect stemming from the significant latent heat of evaporation of water, with little use of electricity (for pumping water to the overhead tank) than the conventional cooling devices. Cooling is achieved without the use of any refrigerants that have high GWP. The growing of plants improves air quality and provides shade. No use of chemical fertilizers, which negatively impacts the soil, water bodies, and the ecosystem. Microplastic release from the use of plastic pipes, drums, and plastic pots, which end up in the landfill or water bodies as plastic debris. Watering of plants could be an issue when there's water scarcity.

1.1.3.2. Potential for Unintended Consequences

Microplastic release from plastic materials (like pipes, drums, pots) can accumulate on land and find its way into the ocean, leading to an imbalance in the terrestrial and aquatic ecosystems.

1.1.3.3. Further Research Needs

Minimizing the use of plastics in the design.

1.2. Socio-Economic Impacts

Literature review, on-field learnings, and community feedback have shown the following socio-economic impacts of the solution.

1.2.1. Negative Socio-Economic Impacts

Impact category	Negative Socio-Economic Impacts - Primary Research	Negative Socio-Economic Impacts - Secondary Research
Health and Well-being	<ul style="list-style-type: none">• None	<ul style="list-style-type: none">• None
Economic	<ul style="list-style-type: none">• Frequent regular care and observation of plants, containers, and roofs is a necessity	<ul style="list-style-type: none">• None
Gender Equality	<ul style="list-style-type: none">• None	<ul style="list-style-type: none">• None
Education	<ul style="list-style-type: none">• None	<ul style="list-style-type: none">• None
Social Cohesion	<ul style="list-style-type: none">• None	<ul style="list-style-type: none">• Uncontrolled and unmanaged foliage and plants from the rooftop garden may create breeding grounds for mosquitoes and other animals like rodents, cats, monkeys, snakes, etc, and may bring potential disturbances to residents and their neighbours
Political	<ul style="list-style-type: none">• None	<ul style="list-style-type: none">• None

Systems		
----------------	--	--

1.2.2. Positive Socio-Economic Impacts

Impact category	Positive Socio-Economic Impacts - Primary Research	Positive Socio-Economic Impacts - Secondary Research
Health and Well-being	<ul style="list-style-type: none"> • Improvement in mental well-being and sleep due to reduced roof temperatures, and physical well-being through gardening activities • More time spent in the house • Feeling happy from harvesting and consuming pesticide-free veggies 	<ul style="list-style-type: none"> • Improvement in air quality and sound insulation positively impacts the overall health of residents
Economic	<ul style="list-style-type: none"> • Reduced energy bills • Fabricated locally • Women-led cooperative can lead micro businesses of gardening, landscaping, and food distribution, fostering economic independence and promoting gender equality 	<ul style="list-style-type: none"> • None
Gender Equality	<ul style="list-style-type: none"> • Women-led cooperative can lead micro businesses of gardening, landscaping, and food distribution, fostering economic independence and promoting gender equality 	<ul style="list-style-type: none"> • None
Education	<ul style="list-style-type: none"> • Community gains hands-on experience of nurturing plants, growing cycles, seasons, and seeds 	<ul style="list-style-type: none"> • None
Social Cohesion	<ul style="list-style-type: none"> • Sharing of harvests regularly with neighbours and sharing of knowledge on seeds, plants, and gardening experience with others improves social relations 	<ul style="list-style-type: none"> • None

Political Systems	<ul style="list-style-type: none"> • None 	<ul style="list-style-type: none"> • None
--------------------------	--	--

1.2.3. Summary

1.2.3.1. Overall Evaluation of Positive & Negative Impacts

Rooftop gardening solution improves mental and physical, and overall well-being of residents because of the reduced roof temperatures, thereby enabling a sound sleep at night. More time spent in the house during summer, growing, cultivating, harvesting, and consuming organic food. It also helps in building social relationships with others by sharing harvests, seeds, and plant knowledge. It reduces energy consumption due to reduced roof temperatures, thereby benefiting the family economically. Women-led cooperatives can form micro-businesses of landscaping, gardening, and food distribution, fostering empowerment and economic independence, creating more job opportunities, and positively impacting the local economy. Regular care and observation of plants, containers, and roofs is required. The unmanaged foliage can become a breeding ground for mosquitoes, attract rodents, cats, snakes etc.

1.2.3.2. Potential for Unintended Consequences

During the winter season, well-spread rooftop gardens may block sunrays hitting roofs, thereby resulting in lower in-house temperatures and potentially keeping residents colder than without the solution.

1.2.3.3. Further Research Needs

Integration of a rainwater harvesting system to reduce the water need/ address the water scarcity for gardening activities needs further research.

2. PET Bottles

Primary Raw Materials - PET Bottles, MLP, Plastic crates

2.1. Environmental Impacts

2.1.1. Negative Environmental Impacts

Table 1: Negative Environmental Impacts - PET Bottles solution

Life Cycle Stage / Environmental Impact Category	(1) Global Warming / Climate Change/Air Pollution	(2) Acidification	(3) Eutrophication (Terrestrial / Aquatic)	(4) Combined Toxicity (Human Health, Fresh water, Terrestrial and Marine)	(5) Photochemical oxidant formation	(6) Land Use	(7) Ozone Depletion	(8) Resource Depletion - Water, Energy	(9) Resource Depletion- Mineral, Fossil Renewables	(10) Solid Waste
Raw Material Acquisition	None	None	None	None	None	None	None	None	None	None
Manufacturing	None	None	None	None	None	None	None	None	None	Discarded bottles, soiled bottles,

										Water bottle labels/ stickers
Distribution /Transportation	None	None	None	None	None	None	None	None	None	None
Use/Reuse/Maintenance	None	Microplastic release from PET bottles, and crates is to be researched	Microplastic release from PET bottles, and crates is to be researched	Microplastic release from PET bottles, and crates is to be researched	None	None	None	None	None	None
End-of-Life	Incineration of bottles, crates leads to significant GHG emissions ⁴	Microplastic release from PET bottles, and crates	Microplastic release from PET bottles, and crates	Incineration leads to release of pollutants like dioxin, furan, sulfur oxides (SOx), posing risk to human health and are hazardous to both land and sea environment	Incineration of bottles, crates leads to significant emissions ⁸	PET bottles ⁹ , Crates may end up at landfill	None	None	None	PET bottles, crates

⁴ Sustainability Life Cycle Environmental Impacts of PET Plastic Water Bottles. (n.d.). Nems.nih.gov. <https://nems.nih.gov/sustain/Pages/PETWaterBottleImpact.aspx>

⁸ Sustainability Life Cycle Environmental Impacts of PET Plastic Water Bottles. (n.d.). Nems.nih.gov. <https://nems.nih.gov/sustain/Pages/PETWaterBottleImpact.aspx>

⁹ Sustainability Life Cycle Environmental Impacts of PET Plastic Water Bottles. (n.d.). Nems.nih.gov. <https://nems.nih.gov/sustain/Pages/PETWaterBottleImpact.aspx>

				<p>s. Plastic pollution and microplastics in drinking water, freshwater⁵ and the environment⁶</p> <p>Chemicals used in plastics are found to be present in the human population and plastic debris are ingested by wildlife⁷</p>						
--	--	--	--	---	--	--	--	--	--	--

2.1.2. Positive Environmental Impacts

Life Cycle Stage / Environmental	(1)	(2)	(3)	(4)	(5)	(6)	(7)	(8)	(9)	(10)
	Global Warming /	Acidification	Eutrophication	Combined Toxicity	Photochemical oxidant	Land Use	Ozone Depletion	Resource Depletion -	Resource Depletion-	Solid Waste

⁵ Microplastics in drinking-water. Geneva: World Health Organization; 2019. Licence: CC BY-NC-SA 3.0 IGO

⁶ Sustainability Life Cycle Environmental Impacts of PET Plastic Water Bottles. (n.d.). Nems.nih.gov. <https://nems.nih.gov/sustain/Pages/PETWaterBottleImpact.aspx>

⁷ Thompson, R. C., Moore, C. J., vom Saal, F. S., & Swan, S. H. (2009). Plastics, the environment and human health: current consensus and future trends. *Philosophical Transactions of the Royal Society B: Biological Sciences*, 364(1526), 2153–2166. <https://doi.org/10.1098/rstb.2009.0053>

Impact Category	Climate Change/Air Pollution		(Terrestrial / Aquatic)	(Human Health, Fresh water, Terrestrial and Marine)	formation			Water, Energy	Mineral, Fossil Renewables	
Raw Material Acquisition	No use of virgin materials	None	None	None	None	None	None	None	None	Reuse of the bottles and crates that would have ended up in landfill
Manufacturing	No process-related emissions as bottles are reused	None	None	None	None	None	None	None	None	None
Distribution/Transportation	None	None	None	None	None	None	None	None	None	None
Use/Reuse/Maintenance	Use of water-filled PET bottles provides thermal comfort by employing passive cooling principle ie., without the use of electricity,	None	None	None	None	None	None	Use of water-filled PET bottles provides thermal comfort by employing passive cooling principle ie., without the use of	None	None

	and hence no electricity-related GHG emissions. Cooling is achieved without the use of refrigerants that have high GWP							electricity and hence no strain on the energy		
End-of-Life	None	None	None	None	None	None	None	Water can be reused for cleaning and flushing purposes	None	None

2.1.3. Summary

2.1.3.1. Overall Evaluation of Positive & Negative Impacts

Use of water-filled PET bottles provides thermal comfort by employing passive cooling principle i.e., without the use of electricity hence no electricity-related GHG emissions. The cooling is achieved without the use of high GWP refrigerants. Reusing PET bottles has a positive impact on the environment as there's no extraction of virgin materials. If not reused, the used PET bottles would have been incinerated (for energy purposes) or end up in a landfill, having a significant negative impact on the environment. Incineration produces significant GHG emissions, releases dioxins and furans, which can accumulate in the environment and living organisms, thereby posing risks to human health and the ecosystem. Fly ash is also a by-product of the incineration process which can end up in landfills. Microplastics are everywhere in the environment. Chemicals used in plastic are found to be present in the human population and plastic debris are ingested by wildlife.

2.1.3.2. Potential for Unintended Consequences

Microplastic release, which can accumulate on land and find its way into the ocean, leading to an imbalance in the terrestrial and aquatic ecosystems

2.1.3.3. Further Research Needs

The effect of acid rain on the PET bottles, crates, and the effect of acid rain leachate on terrestrial and aquatic ecosystems needs further research.

2.2. Socio-Economic Impacts

Literature review, on-field learnings, and community feedback have shown the following socio-economic impacts of the solution.

2.2.1. Negative Socio-Economic Impacts

Impact category	Negative Socio-Economic Impacts - Primary Research	Negative Socio-Economic Impacts - Secondary Research
Health and Well-being	<ul style="list-style-type: none">• None	<ul style="list-style-type: none">• Most of the PET bottles end up in landfills or are incinerated, leading to pollution and environmental degradation, thereby affecting the quality of life
Economic	<ul style="list-style-type: none">• None	<ul style="list-style-type: none">• Mostly, people from lower economic strata are involved in collecting the PET bottles from the unsegregated wastes or from the landfill
Gender Equality	<ul style="list-style-type: none">• None	<ul style="list-style-type: none">• None
Education	<ul style="list-style-type: none">• None	<ul style="list-style-type: none">• None

Social Cohesion	<ul style="list-style-type: none"> • None 	<ul style="list-style-type: none"> • None
Political Systems	<ul style="list-style-type: none"> • None 	<ul style="list-style-type: none"> • None

2.2.2. Positive Socio-Economic Impacts

Impact category	Positive Socio-Economic Impacts - Primary Research	Positive Socio-Economic Impacts - Secondary Research
Health and Well-being	<ul style="list-style-type: none"> • Use of water-filled PET bottles has been shown to reduce the internal room temperature during summer, thereby providing thermal comfort and improving health and livelihood 	<ul style="list-style-type: none"> • None
Economic	<ul style="list-style-type: none"> • Use of water-filled PET bottles has been shown to reduce the internal room temperature during summer, thereby providing thermal comfort without the use of electricity 	<ul style="list-style-type: none"> • None
Gender Equality	<ul style="list-style-type: none"> • None 	<ul style="list-style-type: none"> • None
Education	<ul style="list-style-type: none"> • None 	<ul style="list-style-type: none"> • None
Social Cohesion	<ul style="list-style-type: none"> • None 	<ul style="list-style-type: none"> • None

2.2.3. Summary

2.2.3.1. Overall Evaluation of Positive & Negative Impacts

Use of water-filled PET bottles has been shown to reduce the internal room temperature during summer, thereby providing thermal comfort and improving health and livelihood. It provides cooling by employing passive cooling principle i.e., without the use of electricity, hence there's no additional electricity usage and no strain on the energy supply grid. The majority of plastic ends up in landfills or is incinerated, causing plastic pollution and environmental degradation, posing risks to human health and the ecosystem. Mostly people from lower economic strata are involved in collection, sorting of bottles from unsegregated wastes and landfills.

2.2.3.2. Potential for Unintended Consequences

None

2.2.3.3. Further Research Needs

None

3. Multi-Layered Plastic (MLP)

According to the Plastic Waste Management (PWM) Rules 2016, Multi-Layer Plastic (MLP) is “any material used for packaging and having at least one layer of plastic as the main ingredient in combination with one or more layers of materials such as paper, paper board, polymeric materials, metalised layers or aluminium foil, either in the form of laminate or co-extruded structure.”

3.1. Environmental Impacts

3.1.1. Negative Environmental Impacts

Table 1: Negative Environmental Impacts - MLP

Life Cycle Stage / Environmental Impact Category	(1) Global Warming / Climate Change/Air Pollution	(2) Acidification	(3) Eutrophication (Terrestrial / Aquatic)	(4) Combined Toxicity (Human Health, Fresh water, Terrestrial and Marine)	(5) Photochemical oxidant formation	(6) Land Use	(7) Ozone Depletion	(8) Resource Depletion - Water, Energy	(9) Resource Depletion- Mineral, Fossil Renewables.	(10) Solid Waste
Raw Material Acquisition	None	None	None	None	None	None	None	None	None	None
Manufacturing	None	None	None	None	None	None	None	None	None	None
Distribution/Transportation	None	None	None	None	None	None	None	None	None	None
Use/Reuse/Maintenance	None	Microplastic release is to be researched	Microplastic release is to be researched	Microplastic release is to be researched	None	None	None	None	None	None
End-of-Life	Incineration leads to	None	Microplastic release to be	Incineration leads to the	Incineration leads to	Soiled and discarded	None	None	None	Difficult to recycle

	harmful emissions ¹⁰		researched ^{11,12}	release of toxic by-products - chlorinated dioxins and furans, and fly ash ¹³	harmful emissions ¹⁴	MLPs end up at the landfill				
--	---------------------------------	--	-----------------------------	--	---------------------------------	-----------------------------	--	--	--	--

3.1.2. Positive Environmental Impacts

Life Cycle Stage / Environmental Impact Category	(1) Global Warming / Climate Change/Air Pollution	(2) Acidification	(3) Eutrophication (Terrestrial / Aquatic)	(4) Combined Toxicity (Human Health, Fresh water, Terrestrial and Marine)	(5) Photochemical oxidant formation	(6) Land Use	(7) Ozone Depletion	(8) Resource Depletion - Water, Energy	(9) Resource Depletion- Mineral, Fossil Renewables	(10) Solid Waste
Raw Material	No use of virgin materials	None	None	None	None	None	None	None	None	Reuse of the MLPs that

¹⁰ Anwar, Mayrianti Annisa, et al. "Challenges and Prospects of Multilayer Plastic Waste Management in Several Countries: A Systematic Literature Review." Case Studies in Chemical and Environmental Engineering, vol. 10, no. Volume 10, 28 Aug. 2024, p. 100911, www.sciencedirect.com/science/article/pii/S2666016424003050, <https://doi.org/10.1016/j.cscee.2024.100911>.

¹¹ Anwar, Mayrianti Annisa, et al. "Challenges and Prospects of Multilayer Plastic Waste Management in Several Countries: A Systematic Literature Review." Case Studies in Chemical and Environmental Engineering, vol. 10, no. Volume 10, 28 Aug. 2024, p. 100911, www.sciencedirect.com/science/article/pii/S2666016424003050, <https://doi.org/10.1016/j.cscee.2024.100911>.

¹² Geyer, Roland, et al. "Production, Use, and Fate of All Plastics Ever Made." Science Advances, vol. 3, no. 7, 19 July 2017, www.science.org/doi/10.1126/sciadv.1700782, <https://doi.org/10.1126/sciadv.1700782>.

¹³S, Gayathri Devi. "Multi-Layered Plastics: Why Should It Be Banned? | CAG." Www.cag.org.in, 2 Apr. 2024, www.cag.org.in/newsletters/public-newsense/multi-layered-plastics-why-should-it-be-banned.

¹⁴ Anwar, Mayrianti Annisa, et al. "Challenges and Prospects of Multilayer Plastic Waste Management in Several Countries: A Systematic Literature Review." Case Studies in Chemical and Environmental Engineering, vol. 10, no. Volume 10, 28 Aug. 2024, p. 100911, www.sciencedirect.com/science/article/pii/S2666016424003050, <https://doi.org/10.1016/j.cscee.2024.100911>.

Acquisition										would have ended up in landfill
Manufacturing	No process-related emissions as MLPs are reused	None	None	None	None	None	None	None	None	None
Distribution/Transportation	None	None	None	None	None	None	None	None	None	None
Use/Reuse/Maintenance	Use of MLP as a radiant barrier provides thermal comfort by employing passive cooling principle ie., without the use of electricity, and hence no electricity related GHG emissions. Cooling is achieved without the use of refrigerants that have high	None	None	None	None	None	None	Use of MLP as a radiant barrier provides thermal comfort by employing passive cooling principle ie., without the use of electricity and hence no strain on the energy	None	None

	GWP									
End-of-Life	None	None	None	None	None	None	None	None	None	None

3.1.3. Summary

3.1.3.1. Overall Evaluation of Positive & Negative Impacts

MLPs are ubiquitous in the environment; therefore, the reuse of MLPs has a positive impact, which would have ended up in landfills, and thus avoids the extraction of virgin raw materials. Use of MLPs as a radiant barrier provides thermal comfort by employing passive cooling principle i.e., without the use of electricity, hence no electricity-related GHG emissions. The cooling is achieved without the use of refrigerants that has high GWP. Recycling of MLPs is difficult because of their complex composition. Soiled MLPs are discarded, may end up at a landfill or may be incinerated. Incineration of wastes releases dioxins and furans, which can accumulate in the environment and living organisms, posing risks to human health and the ecosystem. Fly ash is also a by-product of the incineration process can end up in landfills.

3.1.3.2. Potential for Unintended Consequences

MLPs exposure to extreme weather may release microplastics, which can accumulate on land and find its way into the ocean, leading to an imbalance in the terrestrial and aquatic ecosystems.

3.1.3.3. Further Research Needs

Effect of acid rain on the MLP, and the effect of acid rain leachate on terrestrial and aquatic ecosystems need further research.

3.2. Socio-Economic Impacts

Literature review, on-field learnings, and community feedback have shown the following socio-economic impacts of the solution.

3.2.1. Negative Socio-Economic Impacts

Impact category	Negative Socio-Economic Impacts - Primary Research	Negative Socio-Economic Impacts - Secondary Research
Health and Well-being	<ul style="list-style-type: none"> • None 	<ul style="list-style-type: none"> • Due to challenges in recycling, much of MLPs end up in landfill or are incinerated, leading to pollution and environmental degradation, thereby affecting the quality of life.
Economic	<ul style="list-style-type: none"> • None 	<ul style="list-style-type: none"> • Recycling of MLPs is labour, energy intensive and often people from lower economic strata are employed and exploited
Gender Equality	<ul style="list-style-type: none"> • None 	<ul style="list-style-type: none"> • None
Education	<ul style="list-style-type: none"> • None 	<ul style="list-style-type: none"> • None
Social Cohesion	<ul style="list-style-type: none"> • None 	<ul style="list-style-type: none"> • None
Political Systems	<ul style="list-style-type: none"> • None 	<ul style="list-style-type: none"> • None

3.2.2. Positive Socio-Economic Impacts

Impact category	Positive Socio-Economic Impacts - Primary Research	Positive Socio-Economic Impacts -Secondary Research
-----------------	--	---

Health and Well-being	<ul style="list-style-type: none"> • Use of MLPs as a radiant barrier has been shown to reduce the internal room temperature during summer, thereby providing thermal comfort and improving health and livelihood 	<ul style="list-style-type: none"> • None
Economic	<ul style="list-style-type: none"> • Use of MLPs as a radiant barrier has shown to reduce the internal room temperature during summer thereby providing thermal comfort without the use of electricity • Training women in MLP panel fabrication equips them with valuable technical skills and fosters economic independence and promotes gender equality 	<ul style="list-style-type: none"> • Collection and selling of MLP wastes to aggregator generates income¹⁵
Gender Equality	<ul style="list-style-type: none"> • Training women in MLP panel fabrication equips them with valuable technical skills and fosters economic independence and promotes gender equality 	<ul style="list-style-type: none"> • Well-recognised and established NGO's have a structured way to engage with women from lower economic strata and empower them with skills to enable them to upcycle MLPs and earn
Education	<ul style="list-style-type: none"> • None 	<ul style="list-style-type: none"> • Learning skills to upcycle MLPs
Social Cohesion	<ul style="list-style-type: none"> • Women-led cooperatives can be formed where the women trained in MLP fabrication can leverage their expertise and create sustainable livelihoods 	<ul style="list-style-type: none"> • None
Political Systems	<ul style="list-style-type: none"> • None 	<ul style="list-style-type: none"> • None

3.2.3. Summary

3.2.3.1. Overall Evaluation of Positive & Negative Impacts

¹⁵ "MLP Collection – SWaCH." Swachcoop.com, 2021, swachcoop.com/initiatives/mlp-collection/. Accessed 25 Aug. 2025.

The positive impacts include improved health and livelihood, as MLPs can be a cost-effective solution to address thermal comfort better than Alufoil foam and Alufoil double-sided foam¹⁶. As it provides cooling based on passive cooling principle ie., without the use of electricity thereby there's no additional electricity usage and no strain on the energy supply grid. Collection, segregation, sorting, cleaning, and upcycling of MLPs generate income and empower women from the lower economic strata, fostering economic independence and promoting gender equality. These women can form and lead cooperatives and leverage their expertise to create sustainable livelihoods. On the negative impacts, MLPs are difficult to recycle due to their complex composition, because of which the majority of them end up at landfills or are incinerated, causing pollution and environmental degradation, and recycling is labour and energy-intensive, often exploitative.

3.2.3.2. Potential for Unintended Consequences

None

3.2.3.3. Further Research Needs

None

4. Biomass Panels

Primary Raw Materials - Fibres of plants like Sunhemp, wild and domesticated Roselle, wild and domesticated Okra, and Besharam grass.

4.1. Environmental Impacts

Table 1: Negative Environmental Impacts - Biomass panels

4.1.1. Negative Environmental Impacts

¹⁶ CBalance study

Life Cycle Stage / Environmental Impact Category	(1) Global Warming / Climate Change/Air Pollution	(2) Acidification	(3) Eutrophication (Terrestrial / Aquatic)	(4) Combined Toxicity (Human Health, Fresh water, Terrestrial and Marine)	(5) Photochemical oxidant formation	(6) Land Use	(7) Ozone Depletion	(8) Resource Depletion - Water, Energy	(9) Resource Depletion- Mineral, Fossil Renewables	(10) Solid Waste
Raw Material Acquisition	Harvesting wild biomass may lead to vegetation disturbance, releasing stored carbon ¹⁷	None	None	None	None	None	None	None	None	None
Manufacturing	None	None	None	Although sodium carbonate is a mild alkaline with limited toxicity, untreated discharge of sodium carbonate containing wastewater	None	None	None	None	Firewood is renewable but may lead to local depletion if sourced unsustainably	None

¹⁷ Achat, D. L., Fortin, M., Landmann, G., Ringeval, B., & Augusto, L. (2015). Forest soil carbon is threatened by intensive biomass harvesting. *Scientific Reports*, 5, 15991. <https://doi.org/10.1038/srep15991>

				can increase pH and disrupt aquatic ecosystems, potentially harming sensitive organisms such as freshwater sponges ¹⁸						
Distribution/Transportation	None	None	None	None	None	None	None	None	None	None
Use/Reuse/Maintenance	None	None	None	None	None	None	None	None	None	None
End-of-Life	None	None	Nutrient leaching could contribute locally, if biomass panels are composted ¹⁹	None	None	None	None	None	None	None

¹⁸Mukherjee, S., Ray, M., Dutta, M. K., Acharya, A., Mukhopadhyay, S. K., & Ray, S. (2015). Morphological alteration, lysosomal membrane fragility and apoptosis of the cells of Indian freshwater sponge exposed to washing soda (sodium carbonate). *Ecotoxicology and Environmental Safety*, 122, 331–342. <https://doi.org/10.1016/j.ecoenv.2015.08.011>

¹⁹ Venner, K. H., Prescott, C. E., & Preston, C. M. (2009). Leaching of nitrogen and phenolics from wood waste and co-composts used for road rehabilitation. *Journal of Environmental Quality*, 38(1), 281–290. <https://doi.org/10.2134/jeq2007.0595>

4.1.2. Positive Environmental Impacts

Life Cycle Stage / Environmental Impact Category	(1) Global Warming / Climate Change/Air Pollution	(2) Acidification	(3) Eutrophication (Terrestrial / Aquatic)	(4) Combined Toxicity (Human Health, Fresh water, Terrestrial and Marine)	(5) Photochemical oxidant formation	(6) Land Use	(7) Ozone Depletion	(8) Resource Depletion - Water, Energy	(9) Resource Depletion- Mineral, Fossil Renewables.	(10) Solid Waste
Raw Material Acquisition	Manual harvesting and local sourcing minimise fossil fuel use, thereby reducing greenhouse gas emissions compared to industrial raw material collection ²⁰	None	None	None	None	None	None	None	None	None
Manufacturing	None	None	None	None	None	None	None	None	No synthetic	None

²⁰ Richter, A., & Hölbling, W. (2011). Greenhouse gas emissions of two mechanised wood harvesting methods in comparison with the use of draft horses for logging. *European Journal of Forest Research*, 130(2), 185–195. <https://doi.org/10.1007/s10342-011-0585-2>

									binders or fossil-based inputs used in manufacturing, promoting the use of renewable and local resources	
Distribution/Transportation	None	None	None	None	None	None	None	None	None	None
Use/Reuse/Maintenance	Use of biomass panels provides thermal comfort by employing passive cooling principle ie., without the use of electricity, and hence no electricity-related GHG emissions. Cooling is achieved without the use of refrigerants that have high GWP	None	None	None	None	None	None	Use of biomass panels as a thermal comfort retrofit provides reduced indoor temperatures by employing passive cooling principle ie., without the use of electricity, and hence no	None	None

								strain on the energy		
End-of-Life	None	None	None	None	None	None	None	None	None	None

4.1.3. Summary

4.1.3.1. Overall Evaluation of Positive & Negative Impacts

Biomass panels provides cooling based on passive cooling principle ie., without the use of electricity thereby there's no additional electricity usage and no strain on the energy supply grid. The biomass panel production results in a very low carbon footprint majorly because of manual harvesting and local sourcing, reliance on renewable local biomass and manual labor and low chemical toxicity. These factors enable it to support sustainable land use, biodiversity conservation, and community livelihoods. Meanwhile, it's essential to manage the use of sodium carbonate as it can disrupt freshwater ecosystems, prevent overharvesting of wild plants to protect habitats, and ensure worker safety from smoke exposure during firewood burning.

4.1.3.2. Potential for Unintended Consequences

Workers may experience adverse health effects when firewood is used as the primary fuel source in the manufacturing process.

4.1.3.3. Further Research Needs

There is a need for a better understanding of the environmental fate of chemicals such as sodium carbonate used in fiber processing, including their effects on freshwater ecosystems. Effective treatment and reuse strategies must be developed and evaluated.

4.2. Socio-Economic Impacts

Literature review, on-field learnings, and community feedback have shown the following socio-economic impacts of solution.

4.2.1. Negative Socio-Economic Impacts

Impact category	Negative Socio-Economic Impacts - Primary research	Negative Socio-Economic Impacts - Secondary research
Health and Well-being	<ul style="list-style-type: none"> • None 	<ul style="list-style-type: none"> • Exposure to smoke and pollutants from usage of firewood can pose significant health risks, contributing to respiratory illnesses like pneumonia and cardiovascular diseases²¹
Livelihood	<ul style="list-style-type: none"> • None 	<ul style="list-style-type: none"> • None
Gender Equality	<ul style="list-style-type: none"> • None 	<ul style="list-style-type: none"> • None
Education	<ul style="list-style-type: none"> • None 	<ul style="list-style-type: none"> • None
Social Cohesion	<ul style="list-style-type: none"> • None 	<ul style="list-style-type: none"> • None
Political Systems	<ul style="list-style-type: none"> • None 	<ul style="list-style-type: none"> • None

²¹ Elbayoumi, M., & Albelbeisi, A. H. (2023). Biomass use and its health effects among the vulnerable and marginalized refugee families in the Gaza Strip. *Frontiers in Public Health*, 11, Article 1129985. <https://doi.org/10.3389/fpubh.2023.1129985>

4.2.2. Positive Socio-Economic Impacts

Impact category	Positive Socio-Economic Impacts - Primary Research	Positive Socio-Economic Impacts - Secondary Research
Health and Well-being	<ul style="list-style-type: none"> • Biomass panel production using natural, non-toxic raw materials which reduces exposure to hazardous substances for both workers and end-users • Use of biomass panels as a thermal comfort retrofit has shown to reduce the internal room temperature during summer thereby providing thermal comfort and improving health and livelihood 	<ul style="list-style-type: none"> • None
Livelihood	<ul style="list-style-type: none"> • Women, community groups participate in biomass panel production, stimulating rural economies 	<ul style="list-style-type: none"> • None
Gender Equality	<ul style="list-style-type: none"> • Biomass panel production relies on manual labor and can create employment opportunities for women and marginalized groups in rural and local communities, fostering gender-inclusive economic empowerment 	<ul style="list-style-type: none"> • None
Education	<ul style="list-style-type: none"> • Collaboration between community groups and technical experts enhances awareness of environmental sustainability and renewable resource use 	<ul style="list-style-type: none"> • None
Social Cohesion	<ul style="list-style-type: none"> • Engaging different communities in biomass panel production fosters social cohesion by creating shared economic interests and collaborative networks among farmers, fisherfolk, and artisans, thereby strengthening community bonds 	<ul style="list-style-type: none"> • None
Political Systems	<ul style="list-style-type: none"> • None 	<ul style="list-style-type: none"> • None

4.2.3. Summary

4.2.3.1. Overall Evaluation of Positive & Negative Impacts

Use of biomass panels yields several positive socio-economic impacts. The use of natural, non-toxic materials in panel production not only enhances the sustainability of the product but also safeguards the health and well-being of workers involved in the process. The production also engages women and community groups, supporting rural economy and gender empowerment. Collaboration among diverse stakeholder groups also fosters social cohesion amongst themselves.

4.2.3.2. Potential for Unintended Consequences

As mentioned in section 4.1.3.2.

4.2.3.3. Further Research Needs

None

5. Wood Wool Panel

Primary Raw Materials - Wood Wool Fibres, Cement, and Water

5.1. Environmental Impacts

5.1.1. Negative Environmental Impacts

Table 1: Negative Environmental Impacts - Wood Wool Panels

Life Cycle Stage / Environmental Impact Category	(1) Global Warming / Climate Change/Air Pollution	(2) Acidification	(3) Eutrophication (Terrestrial / Aquatic)	(4) Combined Toxicity (Human Health, Fresh water, Terrestrial and Marine)	(5) Photochemical oxidant formation	(6) Land Use	(7) Ozone Depletion	(8) Resource Depletion - Water, Energy	(9) Resource Depletion- Mineral, Fossil Renewables.	(10) Solid Waste
Raw Material Acquisition	Harvest of wood. Monoculture by growing a specific type of tree for making wood wool fibres ²²	None	Monoculture by growing specific type of tree for making wood wool fibres ²³	Monoculture by growing specific type of tree for making wood wool fibres can lead to low ecological diversity and spread of diseases of pests ²⁴	None	None	None	None	None	None

²² Kochova, K. (2022). Mechanical and physical properties of fibre-cement composites using alternative natural fibres. [Phd Thesis 1 (Research TU/e / Graduation TU/e), Built Environment]. Technische Universiteit Eindhoven

²³ Kochova, K. (2022). Mechanical and physical properties of fibre-cement composites using alternative natural fibres. [Phd Thesis 1 (Research TU/e / Graduation TU/e), Built Environment]. Technische Universiteit Eindhoven

²⁴ Kochova, K. (2022). Mechanical and physical properties of fibre-cement composites using alternative natural fibres. [Phd Thesis 1 (Research TU/e / Graduation TU/e), Built Environment]. Technische Universiteit Eindhoven

Manufacturing	Use of electricity	If wood is not sourced sustainably	If wood is not sourced sustainably	None	If wood is not sourced sustainably	None	None	None	None	None
Distribution/Transportation	Transport of wood logs to the manufacturing industry	None	None	None	Transport of wood logs to the manufacturing industry	None	None	None	None	None
Use/Reuse/Maintenance	None	None	None	None	None	None	None	None	None	None
End-of-Life	None	None	None	None	None	None	None	None	None	None

5.1.2. Positive Environmental Impacts

Life Cycle Stage / Environmental Impact Category	(1)	(2)	(3)	(4)	(5)	(6)	(7)	(8)	(9)	(10)
	Global Warming / Climate Change/Air Pollution	Acidification	Eutrophication (Terrestrial / Aquatic)	Combined Toxicity (Human Health, Fresh water, Terrestrial and Marine)	Photochemical oxidant formation	Land Use	Ozone Depletion	Resource Depletion - Water, Energy	Resource Depletion- Mineral, Fossil Renewables.	Solid Waste
Raw Material Acquisition	Majority of insulation materials in	None	None	None	None	None	None	None	None	None

	the market are fossil-based with high embodied energy, whereas wood wool insulation has lower embodied energy and environmental impact ²⁵									
Manufacturing	Lower energy use compared to conventional insulation materials	None	None	None	None	None	None	None	None	None
Distribution /Transportation	None	None	None	None	None	None	None	None	None	None
Use/Reuse/Maintenance	Use of wood wool fibres provides thermal comfort by employing	None	None	None	None	None	None	Use of wood wool fibres provides thermal comfort by employing	None	None

²⁵ O'Brien, L., Li, L., Friess, W., Snow, J., Herzog, B., & O'Neill, S. (2025). Review of bio-based wood fiber insulation for building envelopes: Characteristics and performance assessment. *Energy and Buildings*, 328, 115114. <https://doi.org/10.1016/j.enbuild.2024.115114>

	passive cooling principle ie., without the use of electricity, and hence no electricity-related GHG emissions. Cooling is achieved without the use of refrigerants that have high GWP							passive cooling principle ie., without the use of electricity and hence no strain on the energy		
End-of-Life	None	None	None	None	None	None	None	None	None	Wood Wool Fibres are biodegradable

5.1.3. Summary

5.1.3.1. Overall Evaluation of Positive & Negative Impacts

Use of wood wool fibres for thermal comfort has a lower environmental impact compared to the widely available materials in the market, which are fossil-based and inorganic materials that consume high energy during extraction and manufacturing. Thermal comfort is achieved by passive cooling principle ie., without the use of electricity hence no electricity-related GHG emissions, and there's no use of refrigerants that have high GWP refrigerants. It is biodegradable and recyclable. The negative impacts arise if the wood is not sourced sustainably and a possibility of monoculture farming, thereby leading to high use of fertilizers and pesticides; contributing to eutrophication, low ecological diversity,

and the spread of diseases of pests. Transportation of wood logs to the manufacturing site is another major contributor to the GHG emissions.

5.1.3.2. Potential for Unintended Consequences

None

5.1.3.3. Further Research Needs

Replacing wood fibres with coir fibres, rice straw, fibres obtained from processing of hemp, jute, and replacing cement with fly ash, rice husk ash, can help reduce the use of primary raw materials and the energy associated with processing and manufacturing.

5.2. Socio-Economic Impacts

Literature review, on-field learnings, and community feedback have shown the following socio-economic impacts of the solution.

5.2.1. Negative Socio-Economic Impacts

Impact category	Negative Socio-Economic Impacts - Primary Research	Negative Socio-Economic Impacts - Secondary Research
Health and Well-being	<ul style="list-style-type: none"> • None 	<ul style="list-style-type: none"> • None
Economic	<ul style="list-style-type: none"> • None 	<ul style="list-style-type: none"> • None
Gender Equality	<ul style="list-style-type: none"> • None 	<ul style="list-style-type: none"> • None
Education	<ul style="list-style-type: none"> • None 	<ul style="list-style-type: none"> • None

Social Cohesion	<ul style="list-style-type: none"> • None 	<ul style="list-style-type: none"> • None
Political Systems	<ul style="list-style-type: none"> • None 	<ul style="list-style-type: none"> • None

5.2.2. Positive Socio-Economic Impacts

Impact category	Positive Socio-Economic Impacts - Primary Research	Positive Socio-Economic Impacts - Secondary Research
Health and Well-being	<ul style="list-style-type: none"> • Use of wood wool fibres as insulation has been shown to reduce the internal room temperature during summer, thereby providing thermal comfort and improving health and livelihood • The installed panels look good aesthetically • The panels are asbestos-free 	<ul style="list-style-type: none"> • None
Economic	<ul style="list-style-type: none"> • Use of wood wool fibres as insulation has been shown to reduce the internal room temperature during summer, thereby providing thermal comfort without the use of electricity 	<ul style="list-style-type: none"> • None
Gender Equality	<ul style="list-style-type: none"> • None 	<ul style="list-style-type: none"> • None
Education	<ul style="list-style-type: none"> • None 	<ul style="list-style-type: none"> • None
Social Cohesion	<ul style="list-style-type: none"> • None 	<ul style="list-style-type: none"> • None
Political	<ul style="list-style-type: none"> • None 	<ul style="list-style-type: none"> • None

Systems		
----------------	--	--

5.2.3. Summary

5.2.3.1. Overall Evaluation of Positive & Negative Impacts

The positive socio-economic impacts include improved health and livelihood as it provides cooling based on the passive cooling principle i.e., without the use of electricity, thereby there's no additional electricity usage and no strain on the energy supply grid. Aesthetically, it looks good. It's biodegradable and asbestos-free.

5.2.3.2. Potential for Unintended Consequences

None

5.2.3.3. Further Research Needs

None

Informal Housing Thermal Comfort

Sustenance Roadmap

August 2025

Introduction

Sleepless summer nights, unbearable daytime temperatures inhibiting household activities, health conditions such as nausea, headaches, heart palpitations and dizziness, are few of the many heat stress related issues plaguing the lives of people from marginalised urban settlements. While people in affluent homes seek thermal comfort through climate-polluting and energy-intensive technologies such as airconditioners (a typical 1-ton split-AC in India consumes as much power as 25 ceiling fans) especially during peak summers, the marginalised often live in cramped, poorly ventilated houses with scant protection from solar heat. Additionally, the affluent often possess backup power sources (diesel generators etc.) to permit constant energy use during planned power-cuts induced by the high-demand of energy for indoor cooling, while the urban poor are unable to even operate a ceiling or floor fan (ventilator) to maintain a modicum of comfort during peak summers, increasing their vulnerability to thermal distress. Women in particular are disproportionately impacted by heat, given that they culturally shoulder a greater proportion of family caregiving work, which requires them to wake up earlier than other members and also spend more time indoors to perform household chores such as cooking and cleaning. With the prevailing climate crisis, temperatures are bound to increase in the coming years. Therefore to alleviate energy burdens and provide affordable indoor cooling to people from marginalised homes, there is a need to resort to retrofitting homes with passive cooling solutions that provide thermal comfort with minimal energy usage.

Given that India's demographic and spatial and socio-economic landscape is dynamic and varied, addressing heat stress through passive cooling warrants resorting to a diversity of solutions as opposed to following a one-size-fit all implementation strategy. For instance, a widely recognized solution is having high reflectance (through coating roofs with white paint) as a singular strategy of cooling the roof, however, this poses severe limitations of maintenance as it needs to be exposed to sun and not covered or hampered through activities, especially in marginalised urban settlements, where the roofs are used for a plurality of purposes and quite often covered with plastic sheets. It is therefore vital to ensure that cooling solutions are sensitive to the socio-ecological and climatic context in the place of implementation. Contextual implementation warrants co-creating and implementing solutions in consultation with impacted households. This is asserted by Venter et al (2019)¹ who suggest that Informal Housing upgrades should not be viewed as merely material upliftment and a 'regenerative development' approach is warranted. In this direction, it is pivotal to pass down the skills required in planning, building and maintaining the upgradation of Informal Housing to settlement inhabitants to ensure sustained efforts without external intervention, and also create micro-economic opportunities within the community.

The sustenance roadmap developed as part of the 'Informal Housing Thermal Comfort Program', therefore, aims to work with women who are disproportionately impacted by heat-stress induced injustices in informal settlements, to foster their transformation from being passive subjects of the ecological oppression of extreme heat stress, energy access inequity, and economic exclusion from the sustainable cooling comfort solutions economy, to being generators of their own solutions and associated dignified, ecologically

¹ Venter, A., Marais, L., & Morgan, H. (2019). Informal settlement upgrading in South Africa: A preliminary regenerative perspective. *Sustainability*, 11(9), 2685.

beneficial, livelihoods. The approach to work towards this is to test the merits and feasibility of establishing local women lead 'Women Heat Action Cooperatives (WEHACs)' by enhancing socio-economically marginalized women's capacities to make and act on decisions related to informal housing heat-stress mitigating upgrades by supporting them with the knowledge and skills to identify, procure, fabricate, install, maintain, and sell informal housing thermal comfort products through engagement with relevant stakeholders.

Additionally, the plan is to work on building an ecosystem of support for WEHACs and residents in need of thermal comfort retrofits, to ensure the sustenance of this endeavour. In this direction the intention is to set up an 'Informal Housing Thermal Comfort One-Stop-Shop (OSS)'. The OSS is intended to serve as - 1) A skill/capacity-building facility to provide WEHACs with technical training/support and entrepreneurial training/support 2) A financial assistance facility to deploy low/zero-interest and/or patient seed-capital from financing partners to WEHACs 3) A networking platform for service providers such as material suppliers, electricians, fabrication and installation persons etc., to connect with WEHACs and vice versa. 4) A matchmaking platform between residents, low/zero-interest and/or patient loan-providing financiers, and WEHACs, to facilitate residents' access to thermal comfort services and financial support for the same. 5) A registration and certification platform for WEHACs, fabricators, installers, and other technical service providers to enhance resilience and entrench the sustenance of the OSS model, in the long-term. Providing financial support through the OSS will involve facilitating collaborations between the WEHACs, and local microfinance institutions, CSRs, impact investors, electric utilities, and other relevant financial partners. While the relationship between financial support from microfinance institutions, CSRs etc might be apparent, financial support from electric utilities is visualized from the perspective of advocating for a Demand Side Management (DSM) program hinging upon the economic argument that greater economic utility of sales of electricity saved by supporting WEHACs and households for weatherized roof retrofit installations in informal settlements, the higher the prospects of selling energy saved due to the installations, to industrial consumers at a higher tariff. Another route to enhance the accessibility of residents from heat-vulnerable informal housing communities to affordable cooling solutions centers on policy advocacy with government bodies to facilitate directing funds from Housing Upgrade Schemes, Heat Action Plans (HAPs), Housing Interest Subsidy Schemes, and other relevant Schemes, that can support WEHACs and members from marginalised urban households in gaining financial support for thermal comfort installations, in addition to advocating for the integration of skill-building programs for WEHACs and fabricators as part of existing schemes and policies.

The roadmap section below details steps to work towards facilitating the formation of the above mentioned heat stress mitigating ecosystem in settlements such as Sultanpuri, Delhi where a set of demonstration/pilot passive cooling installations have been implemented already.

Roadmap

1. Explore The Possibility Of Establishing A Womens Heat Action Cooperative (WEHAC) In The Settlement.

Process :

- Identify existing womens groups (WGs) in the settlement.
- If WGs exist in the settlement, survey the group(s) to understand the opportunities and challenges to setting up a Women Heat Action Cooperative (WEHAC).
- Identify 10-12 women from the settlement who can be potential WEHAC members.
- Organise a 'WEHAC Formation Workshop' with the identified women to - a) Share the overview of the WEHAC endeavour b) Seek their input on the WEHAC establishment plan and, c) Gauge their willingness to participate in the WEHAC endeavour.
- Formalize engagement with 6-8 women willing to be part of the WEHAC.

2. Facilitate The Establishment Of A Pilot WEHAC.

Process :

- Organise an apprenticeship program for WEHAC members comprising :
 - Business planning workshops
 - Fabrication and entrepreneurship training workshops
 - On-ground fabrication, installation coordination and business operation training.
- Identify and recruit partner fabricators to support the WEHAC 'with' WEHAC members.
- Conduct fabricator trainings on thermal comfort retrofit fabrication and installation.
- Provide WEHAC members with seed funds to kick-start the business by initiating work on thermal comfort installations with a set of households² who agree to pay the WEHAC for their service³ based on a no-cost EMI arrangement.
- Based on WEHAC members alignment towards continuing their business after the pilot/training period, provide financial and technical support to the WEHAC till they are confident to operate their business independently and have a stable source of monthly income.

² Can be finalized based on the seed fund amount

³ Diverse payment options e.g. sliding scale payments and patient pay-back i.e. payment at a pace that is comfortable based on the households economic condition etc., should be explored with WEHACs during business planning.

3. Facilitate The Formation Of A 'WEHAC And Resident Support Ecosystem'.

Process :

- Establish an 'Informal Housing Thermal Comfort (Financial And Technical Support) One-Stop-Shop'.
 - Identify potential financial support entities e.g. microfinance institutions, CSRs, philanthropic institutions, electric utilities etc.
 - Collaborate with aligned financial support entities.
 - Develop an online OSS portal.
 - Upload WEHAC and fabricator training content to the online OSS portal.
 - Identify potential training partners for WEHAC and fabricator training.
 - Collaborate with aligned partners to offer periodic/on-request trainings through the OSS.
 - Link financial support entities, trainers, WEHACs, fabricators, residents and other relevant entities through the OSS online portal.
 - Establish a physical OSS centre for residents and WEHAC members who do not have access to digital technology.
 - Conduct periodic reviews (start with monthly reviews and decrease the frequency as time progresses), to identify and integrate necessary upgrades to the digital and physical OSSs in collaboration with WEHAC members.

- Engage in Policy Hacking and Advocacy
 - Identify existing National and State/Municipal Schemes and Policies which can be instrumentalized to :
 - Mandate the provision of a diversity of passive cooling housing retrofits as part of Housing, Disaster Mitigation and Health Programs (eg. Heat Action Plans , Pradhan Mantri Awas Yojana, etc)
 - Provide seed funds and skill building support to WEHACs (e.g. National Urban Livelihood Mission, Municipal/State livelihood programs)
 - Recruit WEHACs to provide thermal comfort-based housing upgrades as part of relevant Government Programs (e.g. PMAY).
 - Provide skill building support for fabricators (e.g. through Municipal/State vocational training programs)
 - Provide thermal comfort retrofit or related house enhancement subsidies to residents of informal settlements. (e.g. Pradhan Mantri Awas Yojana, Housing Repair Financial Assistance Schemes for marginalized classes, etc)
 - Advocate for the integration of informal housing thermal comfort supporting elements (eg. financial assistance, skill building, etc) in identified Schemes/Policies, as applicable, by :
 - Developing policy briefs for identified Schemes/Policies - For this, employ policy tactics such insertion, definition expansion, reinterpretation, and

- repurposing without advocating for ‘new’ schemes/policies and governance apparatus.
 - Organising site visits by policy makers to demonstration installation settlements.
 - Organising policy advocacy roundtables.
- To instrumentalize Schemes/Policies which can be leveraged in their existing form to support relevant housing upgrades (e.g. [Dr. B.R. Ambedkar Awas Navinikarn Yojna](#))⁴
 - :
 - Identify 5 households from the settlement who meet the Scheme eligibility criteria
 - Support households in applying for the Scheme.
 - Identify any impediments to the application process that might hinder applicants access to the Scheme.
 - In case of impediments - Troubleshoot the application process to enhance accessibility to the Scheme's benefits by eligible households.
 - In case of no impediments/after impediments are resolved- Share information about the Scheme with other households who can benefit from the same for structural enhancements/other thermal comfort retrofit costs, as applicable.

⁴ While this Scheme offers financial assistance for house repairs and might not directly support thermal comfort retrofit installation costs, households who are eligible to apply for this Scheme and in need of roof repair/roof structure enhancement work to have thermal comfort retrofits installed in their homes, can avail the Schemes benefits to meet the structural enhancement related installation costs, while thermal comfort retrofit costs can be sourced from elsewhere.